



**Tenau**  
TENAU ELEVATOR



**TENAU**  
ELEVATOR



**TENAU ELEVATOR (CHINA) CO., LTD.**

North of Lianyi Road, Nanxun Economic Development Zone,  
Zhejiang Province  
Tel: +86-572-3765590  
E-mail: [Export@tenau.com.cn](mailto:Export@tenau.com.cn)  
[Http://www.tenau.net](http://www.tenau.net)  
P.C.: 313009

# Contents

Brief	01- 02	Villa cabin decoration	55- 56
Tenau intelligentized factory with internationally advanced manufacturing standard	03- 04	Villa decoration	57- 58
Certificates and Engineering Cases	05- 10	Function Table	59- 60
Passenger Elevator With Machine Room	11	Construction Parameter Villa Elevator	61- 62
Passenger Elevator Machine Roomless	12	Freight Elevator	63
Cabin Decoration(Passenger Elevator)	13- 30	Car elevator	64
Panoramic Elevator	31	Decoration Of Freight elevator & Car elevator	65- 66
Panoramic Elevator 180° half-round observation	32	Function Table	67- 68
Panoramic Elevator 270° three-side observation	33	Freight Elevator Construction Parameter	69
Panoramic Elevator 360° 3D full-view observation	34	Machine Roomless Freight Elevator Construction Parameter	70
Hospital Elevator	35- 36	Car Elevator Construction Parameter	71
Cabin operation Panel	37- 40	Escalator Summary	72
Optional decoration	41- 44	Moving Walk Summary	73
Function Table	45- 46	Heavy Duty Type Escalator	74
Machine Room Passenger Elevator Construction Parameter	47- 48	Escalator Safety Device	75
Machine Roomless Passenger Elevator Construction Parameter	49	Moving Walk Safety Device	76
Hospital Elevator Construction Parameter	50	Standard & Optional Function	77- 78
Machine Room Panoramic Elevator Construction Parameter	51	30° Escalator Construction Parameter	79
Machine Roomless Panoramic Elevator Construction Parameter	52	35° Escalator Construction Parameter	80
Spacious Space Taste Leisurely Life	53	12° Moving walk Construction Parameter	81
Green And Noiseless Design Gives You Healthy Life	54	0° Moving walk Construction Parameter	82

# Brief

TENAU ELEVATOR (CHINA) Co., Ltd., located in Huzhou City, Zhejiang Province, is a wholly-owned investment company by SUZHOU DIAO Elevator Co., Ltd. in 2012, which is specially aimed at the overseas market. TENAU is close to Shanghai, only one hour away by car.

During the initial set-up stage, TENAU has already had professional elevator and escalator production lines, fully automatic panel production equipment - salvagnini, and employed more than 300 people.

In 2016, DIAO Group Ltd consolidated these two factories - DIAO and TENAU, which then have become two production bases, sharing the production platform. DIAO manufactures all the escalators and passenger elevators, and TENAU is responsible for manufacturing all the cargo elevators and home lift.

Brand DIAO has stayed in business for 16 years and accumulated rich experience in production, technology and product development. On this basis, TENAU can better serve overseas customers, at the same time, we can provide multiple languages service, including Russian, Spanish, English and Arabic.

TENAU has obtained energy efficiency certification of TUV for MR and MRL, besides this, our company has also obtained CE certification for MR, MRL of Passenger, ESCALATOR and MOVING WALK.

TENAU owns independent R&D team, which successfully developed and operated the 13m/s elevator on the testing tower with the height of 168 meters.



- 168-meter test tower
- 13 m / s ultra-high speed with independent R & D technology
- High-end intelligent elevator
- Industry 4.0 production system
- Export more than 70 countries in worldwide

# Tenau Modern Intelligentized Factory With Internationally Advanced Manufacturing Standard

The Tenau (China) industry 4.0 production system, which was guided, planned and constructed by the German Tenau elevator group, creates new opportunities for establishment of modern intelligentized factory. Several top automatic production equipment, combined with big data and Internet of Things, can realize intelligent processing, intelligent production, intelligent detection and intelligent monitoring of industry procedures.

## Fully-automatic panel production line-Salvagnini

World top automatic equipment, automatic set-up of processing thickness without the necessity to adjust time and MAC2.0 adaptive technique to guarantee quality.

## SMT paster assembly line

SMT paster assembly line which is second to none in the industry can realize production of outer casing, interface board, power panel and communication panel with international standard.

## Industrial robot

Realize mechanical way of working, adapt to extreme environment and realize multiple tasks, like carrying, welding, and loading and unloading.



# Certificate and Engineering Projects

## Certificates



TUV-CERTIFICATE-ESCALATOR



TUV-CERTIFICATE-MOVING WALK

EN 115-1:2008+A1:2010



CERTIFICATE OF ENERGY EFFICIENCY



CERTIFICATE OF ENERGY EFFICIENCY



TUV-CERTIFICATE-MACHINE ROOM-PASSENGER ELEVATOR



TUV-CERTIFICATE-MACHINE ROOM-PASSENGER ELEVATOR

European Directive 2014/33/EU  
Harmonized Standards EN81-20:2014, EN81-50:2014

## Asia



ICON SIAM Shopping Mall, Bangkok, Thailand



TERMINAL 21 Shopping Mall, Pattaya, Thailand



Hotel Yasmin Karawaci, Indonesia

Subway project, Seoul, South Korea

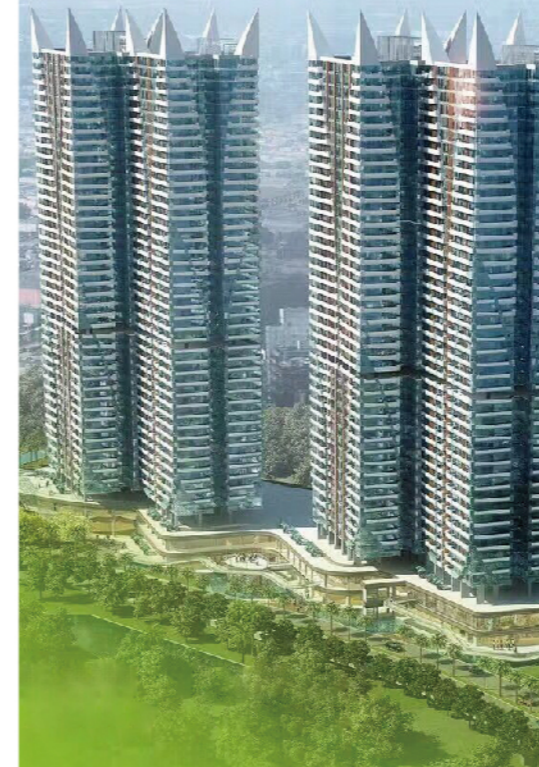

Grand Kamala Lagoon, Jakarta, Indonesia



Porto de Melaka, Malacca, Malaysia



Gangshan Shopping Mall, Kaohsiung, Taiwan

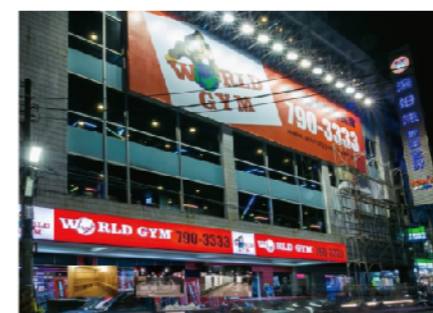

Fengshan Shopping Mall, Kaohsiung, Taiwan

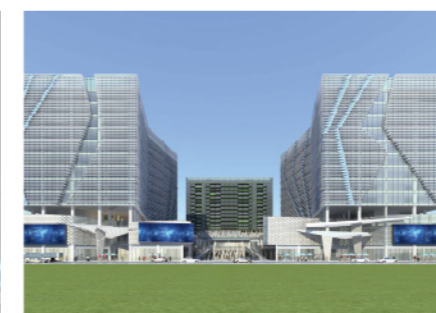

International Plaza, Phnom Penh, Cambodia



Zhiron Garden, Sihanoukville, Cambodia

# Certificate and Engineering Projects

## Latin America



UNITEC, Queretaro, Mexico



TOLUCA, Queretaro, Mexico



Colombia



Parque de Ocio, Bogota, Colombia



Colombia



Colombia



BPS, Montevideo, Uruguay



URQUIZA, Montevideo, Uruguay

## Russian speaking countries



Best Center, St Petersburg, Russia



Moscow Shopping Mall



Moscow Shopping Mall



Hotel, Novosibirsk, Russia



Khabarovsk Airport



Shopping Mall, Novosibirsk, Russia



Pala Group, Tbilisi, Georgia



Administration Building, Vladivostok, Russia

# Certificate and Engineering Projects

## The Middle East



Laleh Building, Mashhad, Iran

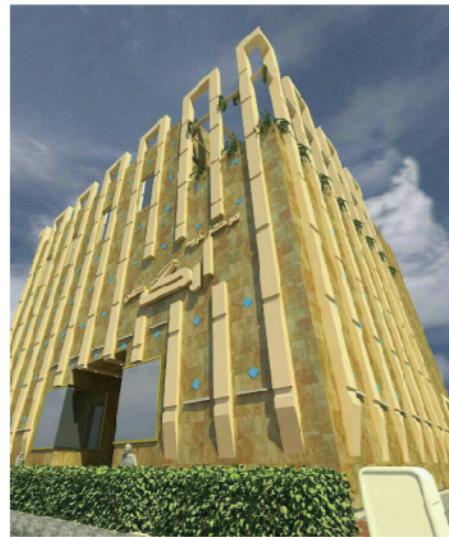

ARG Shopping Mall, Mashhad, Iran



Aftab Shopping Mall, Mashhad, Iran



Sand Rose, Dubai



Bonyad Project, Mashhad, Iran

## Africa



The Leo lifestyle apartments, South Africa



Palm Spring Resort, Liberia

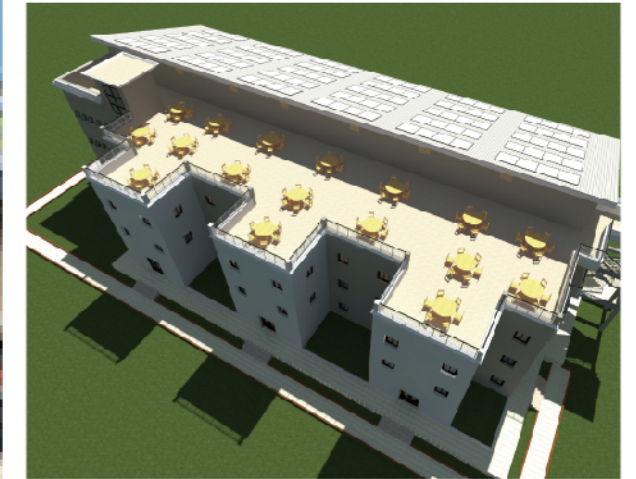

Molecular Lab Building, Banjul, Gambia

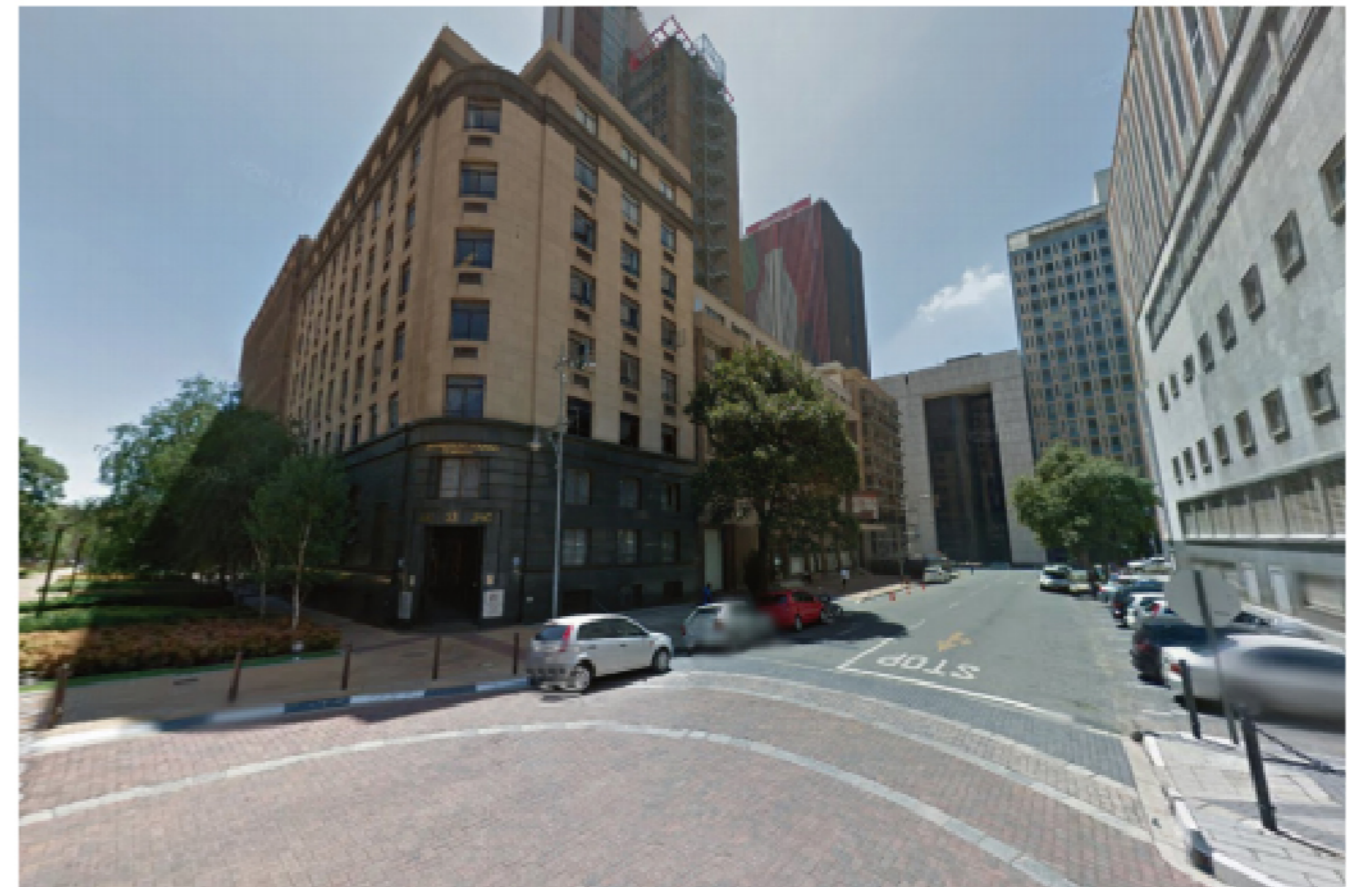

58 Main St, Johannesburg, Gauteng

# Passenger Elevator With Machine Room

Saving room volume

50%

## Space efficiency

The machine room of the elevator only need 50% space of the traditional machine room. Therefore, it provides more possibilities for construction design.

Tenau passenger elevators with small machine room have improved its performance by reducing area of their machine rooms. With advantages in saving floor areas and construction costs, the elevators are applicable to office buildings, hotels and supermarkets.

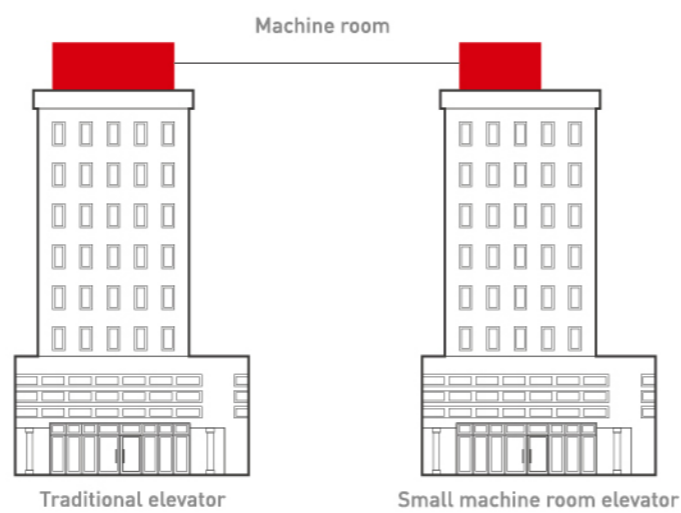
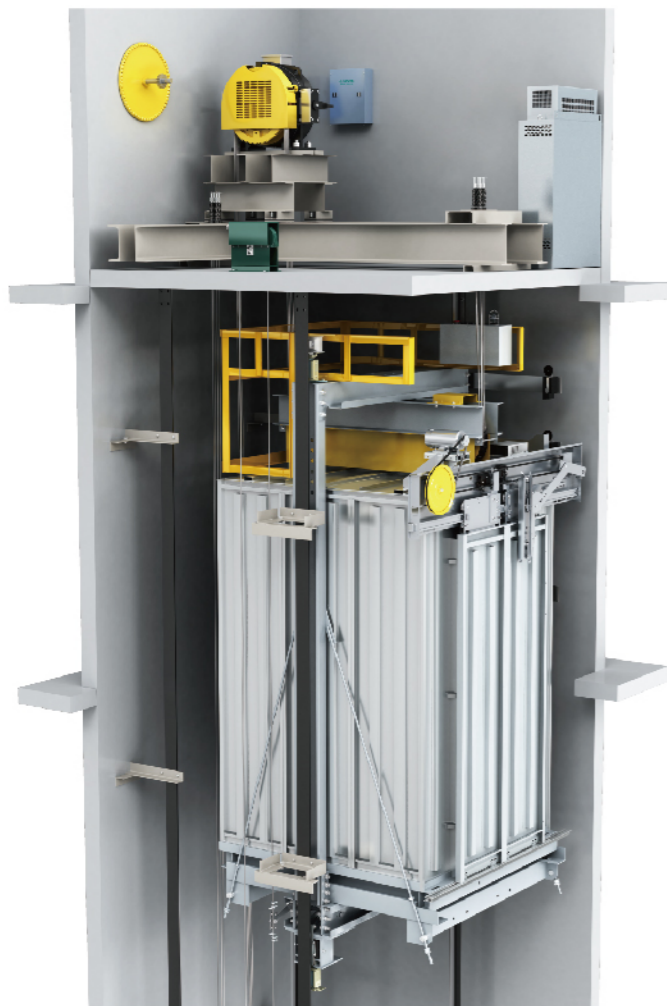

# Passenger Elevator Machine Roomless

Tenau machine roomless passenger elevators eliminate influence of the machine room on construction from the structural aspect, providing more possibilities for construction space arrangement or construction design. Such elevators are applicable to hotels, business buildings high-rises and other buildings with higher requirements for construction.

## Free up the space

The control cabinet and traction machine are installed in inner part of the hoist way, freeing up the original space spared for the machine room. Compared with traditional design, the new mode could save more than 10% of the floor area.

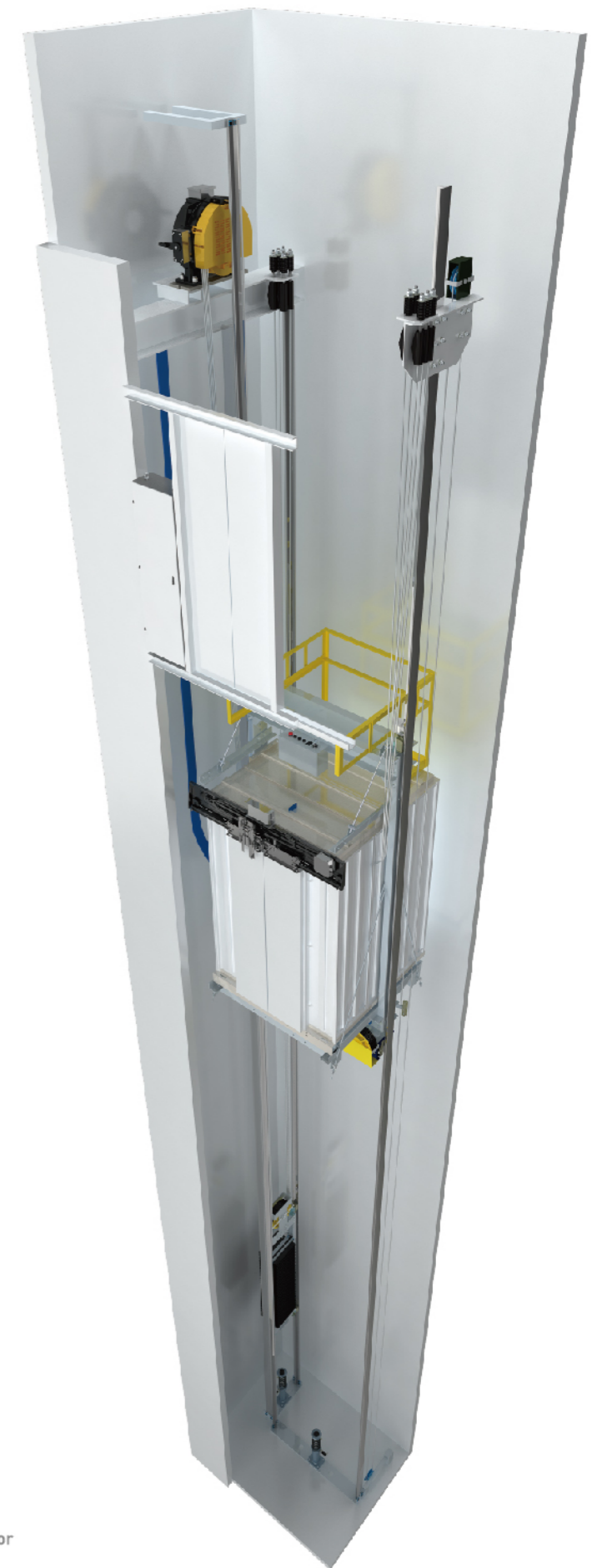
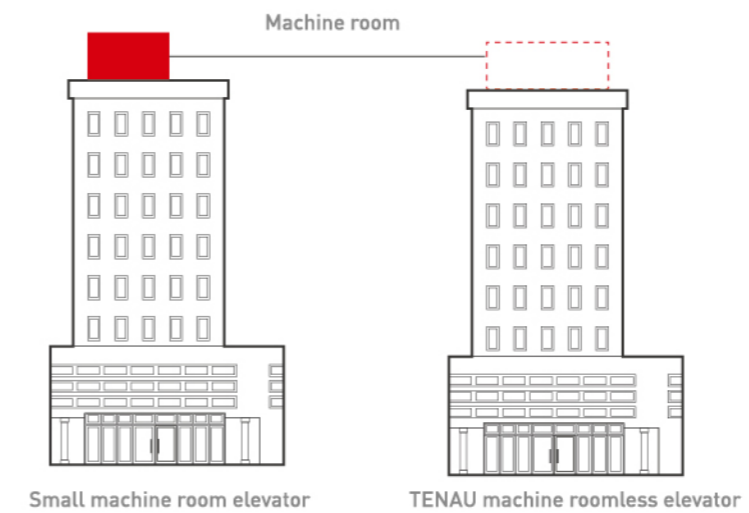

# Cabin Decoration

## Passenger Elevator



### TO-J001

Standard

Integrated Ceiling:  
Painted steel, four sides down lamp  
Car wall and car door: Stainless steel  
Operation panel: Hairline stainless steel  
Floor: PVC floor



### TO-J001

Standard

Integrated Ceiling:  
Painted steel, four sides down lamp  
Car wall and car door:  
Painted steel Light gray  
Operation panel: Hairline stainless steel  
Floor: PVC floor



### TO-J001

Standard

Integrated Ceiling:  
Painted steel, four sides down lamp  
Car wall and car door:  
Painted steel Cream-colored  
Operation panel: Hairline stainless steel  
Floor: PVC floor

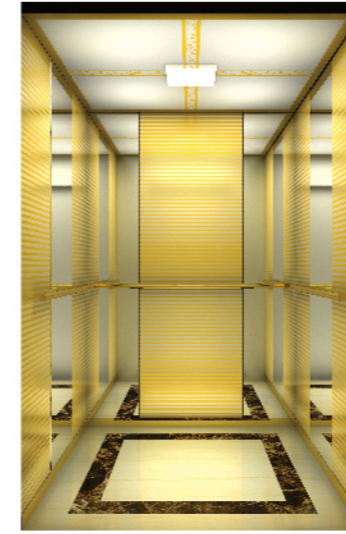

### TO-J005

Optional

Car wall: Mirror stainless steel, titanium stainless steel  
Car door: Mirror stainless steel  
Gatepost: Titanium hairline stainless steel round tube  
Skirtboard: Painted steel  
Floor: PVC



### TO-J006

Optional

Car wall and car door: Mirror stainless steel  
Hairline stainless steel  
Gatepost: Hairline stainless steel  
Skirtboard: Stainless steel or painted steel  
Floor: PVC



### TO-J002

Standard

Integrated Ceiling: Silver membrane, with LED lamp in the middle, vents on both sides  
Car wall and car door/Front wall panel:  
Light grey painted steel plate  
Operation panel: Hairline stainless steel (Separated type)  
Skirting: Stainless steel or painted steel plate  
Floor: PVC floor



### TO-J003

Optional

Car wall and car door: Mirror stainless steel in the Middle, craft wooden facing on the other sides  
Gatepost: Mirror stainless steel  
Skirtboard: Stainless steel  
Floor: PVC



### TO-J004

Optional

Integrated Ceiling: Painted steel, down lamp  
Car wall: Mirror stainless steel in the middle, hairline stainless steel for both sides  
Floor: PVC floor



### TO-J007

Optional

Car wall: Middle with mirror etching stainless steel, side of stainless steel floor with tube lamp of soft illumination design  
Car side and car back: Center board is made of mirror finish, etching finish, hairline finish Auxiliary board is made of hairline finish  
Handrail: Stainless steel round tube  
Floor: PVC



### TO-J008

Optional

Car wall: Painted steel, tube lamp an white transparent board for illumination design  
Car side and car back: Center board is made of mirror finish, etching finish, hairline finish  
Auxiliary board is made of hairline finish  
Handrail: Stainless steel flat handrail  
Floor: PVC

# Cabin Decoration

## Passenger Elevator



### TO-J009

Optional

Ceiling: Painted steel, downlight  
 Car wall: Panel with combination of wood grain and hairline  
 Front wall: Hairline stainless steel  
 Floor: PVC  
 Skirting: Hairline stainless steel



Selection of back panel material



GL-01



GL-02

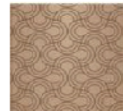

GL-03

### TO-J010

Optional

Ceiling: Mirror stainless steel, Lamp bracket, LED downlight  
 Car wall: Brushed stainless steel  
 Front wall: Art glass, brushed stainless steel  
 Floor: PVC parquet



Selection of back panel material



3699-Rattan

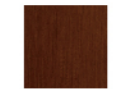

6928-Ch



2567-Copper



1395-Ta

### TO-J011

Optional

Ceiling: Metal baking paint decoration, LED downlight  
 Car wall: Brushed stainless steel  
 Front wall: fire-proof facing with wood grain, Brushed stainless steel  
 Floor: PVC



Selection of back panel material

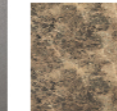

3457 - Br

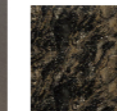

3467 BSt



3465 Gl

### TO-J012

Optional

Ceiling : Metal baking paint decoration, LED downlight  
 Car wall: Brushed stainless steel  
 Front wall: Fire-proof facing with marble texture, Brushed stainless steel  
 Floor: PVC



Selection of back panel material



SK-01



SK-02



SK-03

### TO-J013

Optional

Ceiling: Metal baking paint decoration, Lamp bracket, LED downlight  
 Car wall: Brushed stainless steel  
 Front wall: Brushed stainless steel, black titanium mirror surface with stainless etching, brushed stainless steel side decoration strips and foot lines  
 Floor: PVC

# Cabin Decoration

## Passenger Elevator



### TO-J014

Optional

Ceiling: Hairline stainless steel, down lamp  
 Car wall: Side wall: Hairline stainless steel, mirror stainless steel  
 Rear wall: Hairline stainless steel, mirror etching stainless steel  
 Handrail: Stainless steel, wood  
 Floor: PVC floor



### TO-J015

Optional

Ceiling: Hairline stainless steel, four sides down lamp  
 Car wall: Stainless steel mirror, wood grain laminated plate  
 Floor: PVC floor



### TO-J016

Standard

Ceiling: Mirror stainless-steel modeling, light filter, LED down lamp  
 Car wall: Front wall: Brushed stainless steel  
 Rear wall: Art wallpaper, mirror stainless steel  
 Side wall: Fireproof composite veneer, brushed stainless steel  
 Floor: PVC floor

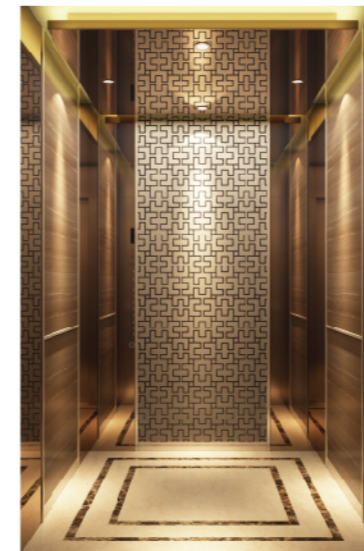

### TO-J017

Optional

Ceiling: Mirror stainless steel, LED down lamp, white stoving varnish and tape lights  
 Car wall: Side wall: mirror stainless steel, fire-proof panel with marbling, brushed stainless steel capping strip, brushed stainless steel skirting line and brushed stainless steel gib  
 Rear wall: mirror stainless steel, art glass, brushed stainless steel capping strip, brushed stainless steel skirting line  
 Floor: Marble parquet



### TO-J018

Optional

Ceiling: Mirror stainless steel, LED down lamp, white stoving varnish and tape lights  
 Car wall: Side wall: Black titanium mirror stainless steel, wood grain fire-proof plate, brushed stainless steel capping strip, brushed stainless steel skirting line, brushed stainless steel and stainless steel handrail  
 Rear wall: Black titanium mirror stainless steel, rose gold mirror stainless steel etching, brushed stainless steel capping strip and brushed stainless steel skirting line  
 Floor: Floor tiles

# Cabin Decoration

## Passenger Elevator



### TO-J019

Optional

Car side and car back: Center board is made of ti-plated finish, mirror finish, etching finish, hairline finish, vibration finish  
 Auxiliary board is made of ti-plated finish, mirror finish  
 Handrail:Ti-plated stainless steel three tube  
 Floor:PVC



### TO-J020

Optional

Car wall and car door: Mirror stainless steel  
 Hairline stainless steel  
 Gatepost: Hairline stainless steel  
 Skirtboard: Stainless steel or paint steel  
 Floor:PVC



### TO-J021

Optional

Ceiling: Titanium gold stainless steel, acrylic  
 Car wall: Titanium gold stainless steel, titanium gold mirror, titanium gold etched stainless steel  
 Handrail: Combination of titanium gold and acrylic bar  
 Floor: PVC



### TO-J022

Standard

Ceiling: Golden painted ceiling, with concealed soft spotlight  
 Car wall: Wooden surface, mirror stainless steel  
 Car door: Mirror stainless steel  
 Floor: Marble floor



### TO-J023

Optional

Ceiling: Rose gold mirror stainless steel frame, acrylic light-emitting panel  
 Car wall: Rose gold mirror etching, marble  
 Handrail: Rose gold flat handrail  
 Floor: PVC

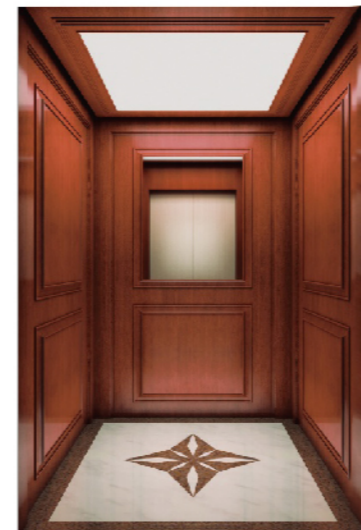

### TO-J024

Optional

Ceiling: Solid wood frame, acrylic light-emitting panel  
 Car wall: Wood grain decoration panel, glass mirror/mirror stainless steel  
 Handrail: None  
 Floor: PVC

# Cabin Decoration

## Passenger Elevator



**TO-J025**

Optional

Cabin walls: Mirror etching hairline stainless steel finish



**TO-J026**

Optional

Cabin walls: Mirror etching hairline stainless steel finish



**TO-J029**

Optional

Cabin walls: Mirror etching hairline stainless steel finish



**TO-J030**

Optional

Cabin walls: Mirror etching hairline stainless steel finish



**TO-J027**

Optional

Cabin walls: Mirror etching hairline stainless steel finish



**TO-J028**

Optional

Cabin walls: Mirror etching hairline stainless steel finish

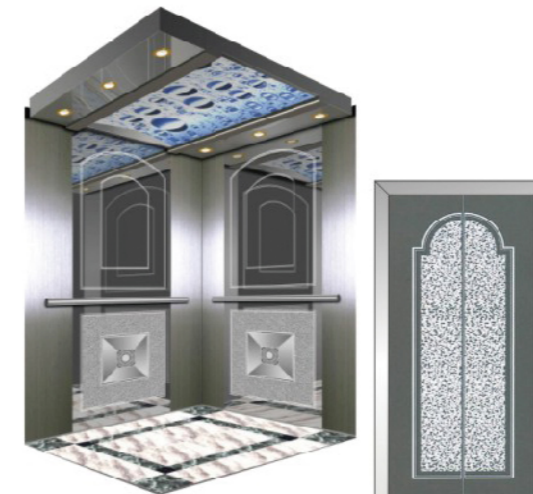

**TO-J031**

Optional

Cabin walls: Mirror etching hairline stainless steel finish

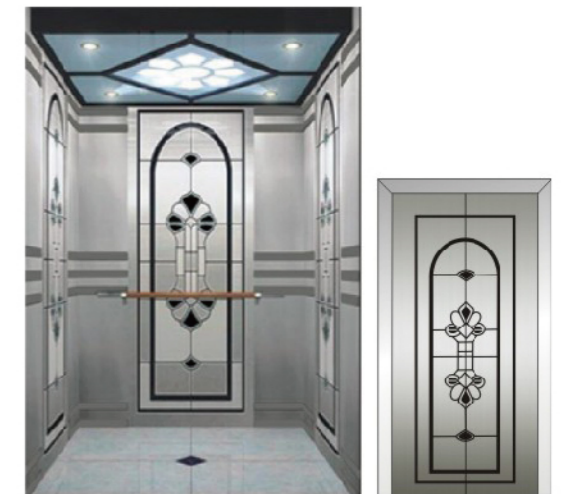

**TO-J032**

Optional

Cabin walls: Mirror etching hairline stainless steel finish

# Cabin Decoration

## Passenger Elevator



### TO-J033

Optional

Cabin walls: Mirror etching hairline stainless steel finish with gold

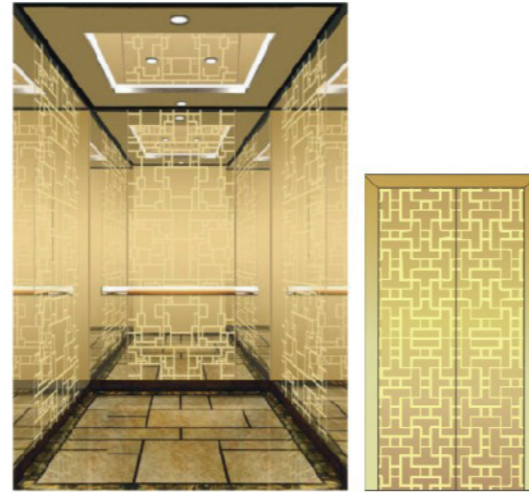

### TO-J034

Optional

Cabin walls: Mirror etching hairline stainless steel finish with gold



### TO-J037

Optional

Cabin walls: Mirror etching hairline stainless steel finish with gold

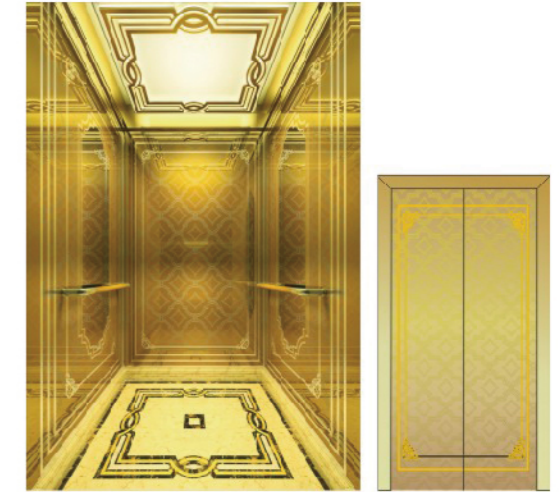

### TO-J038

Optional

Cabin walls: Mirror etching hairline stainless steel finish with gold

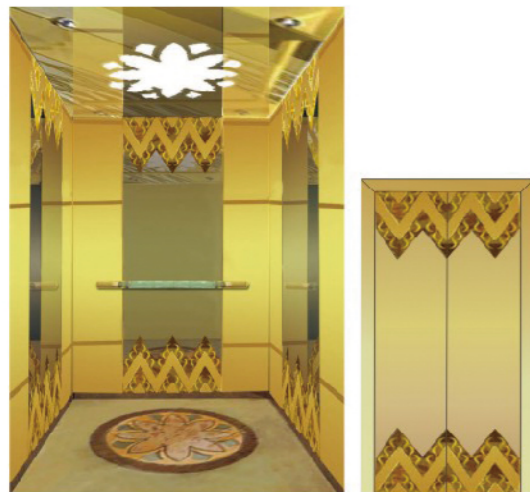

### TO-J035

Optional

Cabin walls: Mirror etching hairline stainless steel finish with gold



### TO-J036

Optional

Cabin walls: Mirror etching hairline stainless steel finish with gold



### TO-J039

Optional

Cabin walls: Mirror etching hairline stainless steel finish with gold



### TO-J040

Optional

Cabin walls: Mirror etching hairline stainless steel finish with gold

# Cabin Decoration

## Passenger Elevator



### TO-J041

Optional

Cabin walls: Mirror etching hairline stainless steel finish

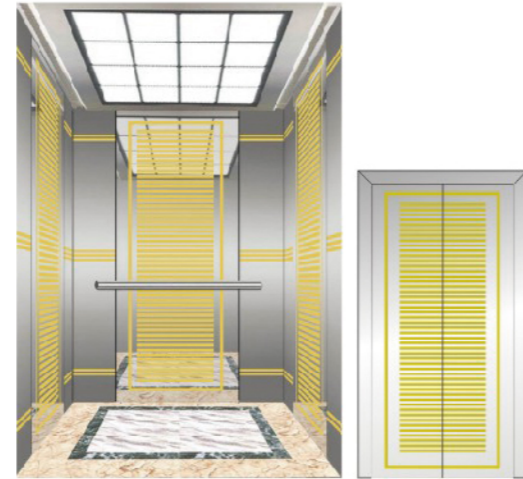

### TO-J042

Optional

Cabin walls: Mirror etching hairline stainless steel finish with gold

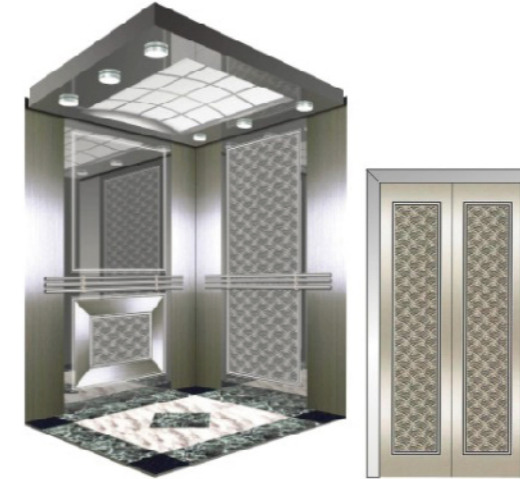

### TO-J045

Optional

Cabin walls: Mirror etching hairline stainless steel finish



### TO-J046

Optional

Cabin walls: Mirror etching hairline stainless steel finish with black gold

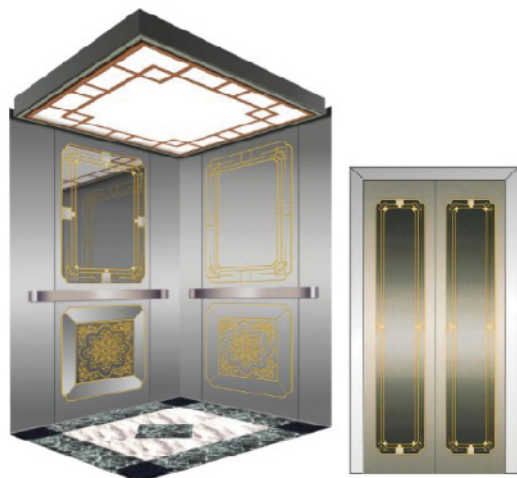

### TO-J043

Optional

Cabin walls: Mirror etching hairline stainless steel finish with gold



### TO-J044

Optional

Cabin walls: Mirror etching hairline stainless steel finish



### TO-J047

Optional

Cabin walls: Mirror etching hairline stainless steel finish

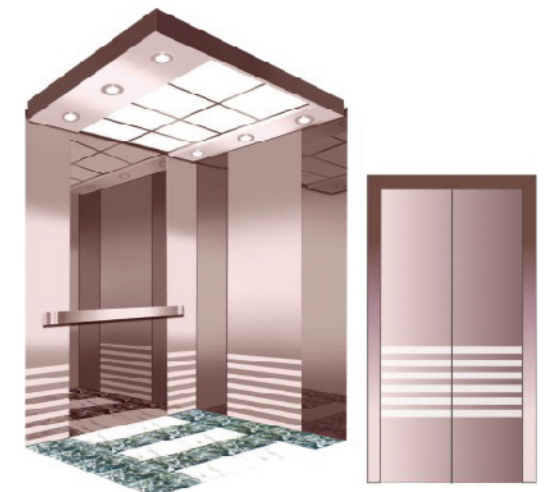

### TO-J048

Optional

Cabin walls: Mirror etching hairline stainless steel finish with rose gold

# Cabin Decoration

## Passenger Elevator

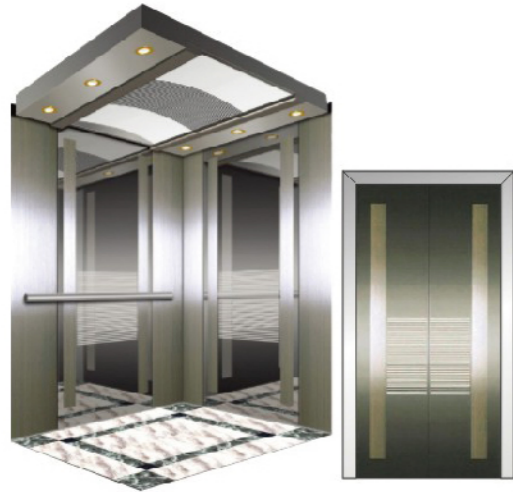

**TO-J049**

Optional

Cabin walls: Mirror etching hairline stainless steel finish

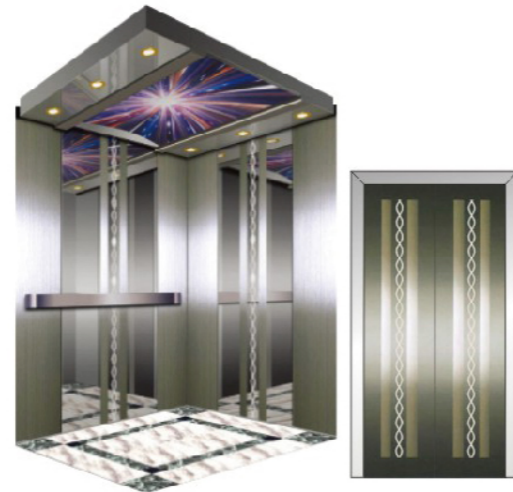

**TO-J050**

Optional

Cabin walls: Mirror etching hairline stainless steel finish



**TO-J053**

Optional

Cabin walls: Mirror etching hairline stainless steel finish

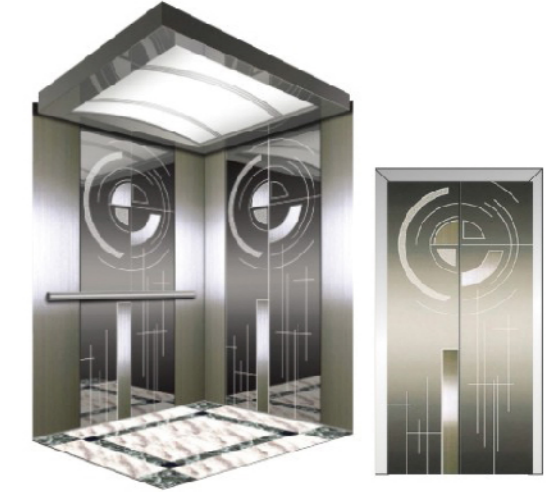

**TO-J054**

Optional

Cabin walls: Mirror etching hairline stainless steel finish



**TO-J051**

Optional

Cabin walls: Mirror etching hairline stainless steel finish



**TO-J052**

Optional

Cabin walls: Mirror etching hairline stainless steel finish



**TO-J055**

Optional

Cabin walls: Mirror etching hairline stainless steel finish



**TO-J056**

Optional

Cabin walls: Mirror etching hairline stainless steel finish

# Cabin Decoration

## Passenger Elevator

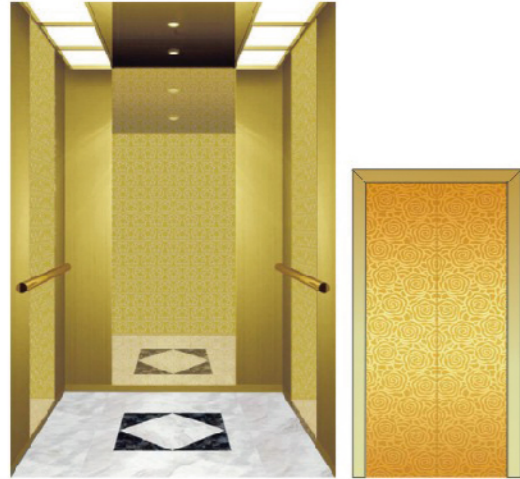

### TO-J057

Optional

Cabin walls: Mirror etching hairline stainless steel finish with gold



### TO-J058

Optional

Cabin walls: Mirror etching hairline stainless steel finish with gold



### TO-J061

Optional

Cabin walls: Mirror etching hairline stainless steel finish with gold

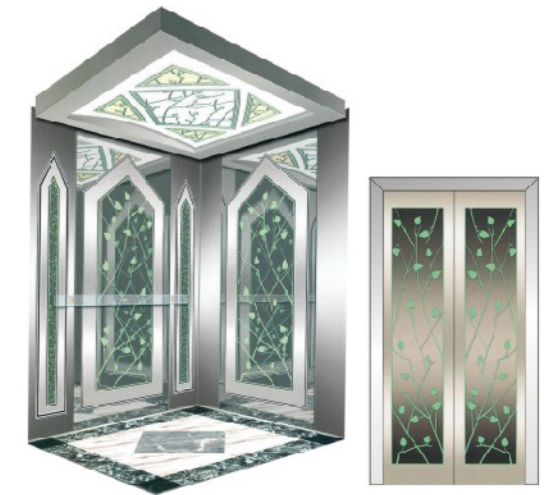

### TO-J062

Optional

Cabin walls: Mirror etching hairline stainless steel finish with green



### TO-J059

Optional

Cabin walls: Mirror etching hairline stainless steel finish with gold

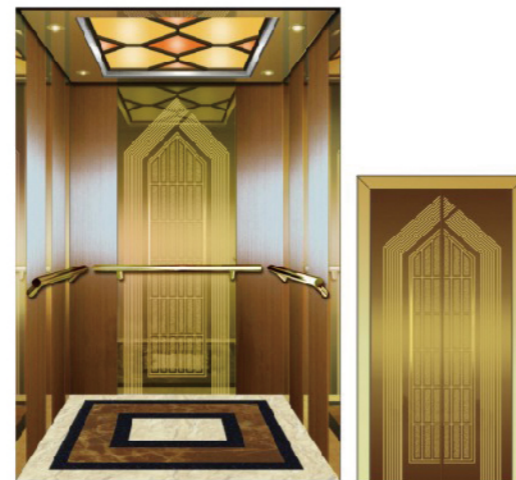

### TO-J060

Optional

Cabin walls: Mirror etching hairline stainless steel finish with gold



### TO-J063

Optional

Cabin walls: Mirror etching hairline stainless steel finish with gold



### TO-J064

Optional

Cabin walls: Mirror etching hairline stainless steel finish with gold

# Panoramic Elevator

Tenau observation elevator adheres to the design principle of innovativeness and fashion. To meet various demands of hotels and supermarkets, our company provides different elevator designs according to their building styles. Delicate style designs provide passengers with different scenic perspectives and broad scenic views.



## Delicate lift car

Tenau provides different decoration options for lift cars, so as to match up facades and interior decoration of various buildings.

## Rich structures

Square, circular and polygon reinforced glass structures offer different scenic perspectives and bring all views to eyes of passengers.

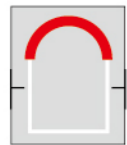

Semi-circular shaped panorama elevator

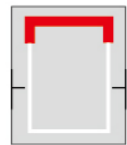

Square shaped panorama elevator

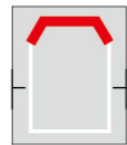

Cutting-angle-type panorama elevator

## Comfortable and stable operation

Our company aims to improve experience of passengers by applying several advanced technologies and creating dynamic and comfortable space. Passengers will feel pleasant and comfortable during stable operation of the elevator.

## Transparent structures for wide views

The elevator adopts safe laminated glass which could offer wide views by its transparent nature. Streamline design and wide views provide passengers with a broad and clear world they have never experienced.



# Panoramic Elevator 180° half-round observation

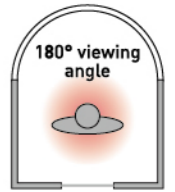

## TO-G001

Standard

Canopy: Painted steel with decoration  
 Observation wall: Three pieces of laminated glass  
 Car Ceiling: Mirror stainless steel  
 Car wall: Hairline stainless steel  
 Handrail: Single tube with stainless steel  
 Car floor: PVC floor



## TO-G002

Standard

Car Cover: Paint steel, tube lamp, acrylic lamp  
 Observation Wall: Laminated glass three pieces  
 Decoration Roof: Acrylic roof lamp  
 Car Wall: Hairline finished St/St  
 Handrail:  $\phi$  38 Stainless steel tube  
 Floor: PVC floor



## TO-G003

Standard

Upper / lower hood: White acrylic  
 Observation wall: Laminated glass (5+5 three pieces)  
 Decoration ceiling: Steel plate plastic, tube lamp  
 Car wall: Hairline stainless steel  
 Handrail:  $\phi$ 38 stainless steel tube  
 Floor: PVC



## TO-G004

Standard

Car Cover: Paint steel plate, decoration lamp  
 Observation Wall: 3PCs of safety laminated glass  
 Decoration Roof: Acrylic roof lamp  
 Car Wall: Hairline plate, etched  
 Handrail: Stainless steel tube  
 Floor: PVC floor

# Panoramic Elevator

## 270° three-side observation

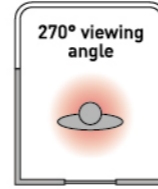

### TO -G005

Standard

Car Cover: Painted steel, Tube Lamp  
 Observation Wall: Laminated glass  
 Decoration Roof: Acrylic lighting cover  
 Car Wall: Hairline Finished St/St  
 Handrail:  $\phi$  25.4 Stainless steel double tube  
 Floor: PVC Floor

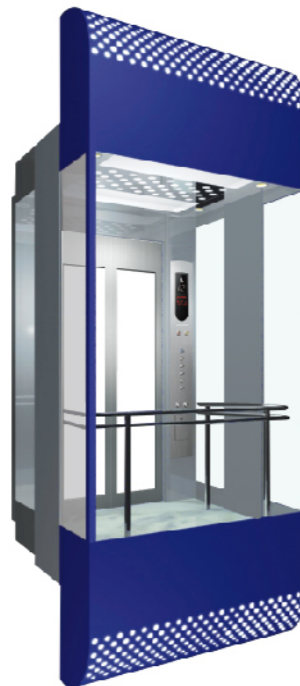

### TO -G006

Standard

Car cover: Baking enamel, lighting decoration  
 Observation wall: Laminated glass safety clamp  
 Decoration ceiling: Mirror finished st./st, acrylic  
 Car wall: Laminated glass  
 Handrail: Stainless steel tube  
 Floor: PVC

# Panoramic Elevator

## 360° 3D full-view observation

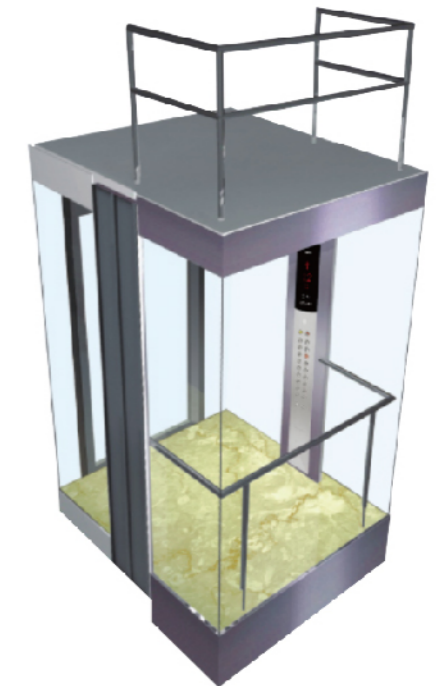
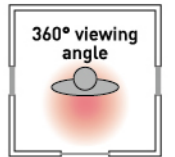

### TO -G007

Standard

Upper/lower shades: Stepped pentagon steel plate banking finish with decoration lamp  
 Ceiling: Middle with acrylic roof lamp, side with tube lamp  
 Side wall and back wall: Stainless steel hairline board  
 Front wall: Laminated glass safety clamp  
 Handrail: Stainless steel round handrail  
 Floor: PVC floor



### TO -G008

Optional

Car cover: Hairline stainless steel, stainless steel mono-tube  
 Observation wall: Safety laminated glass  
 Decoation roof: Mirror stainless steel, light-emitting panel, down lamp  
 Car wall: Hairline stainless steel  
 Handrail: Stainless steel mono-tube  
 Floor: PVC

### TO -G009

Optional

Outer decoration: Mirror ST. ST.  
 Ceiling: Mirror ST. ST., acrylic, LED spotlight  
 Observation wall: Laminated safety glass  
 Walls: Mirror ST. ST.  
 Handrail: ST. ST. tube  
 Flooring: Marble  
 Front wall: Laminated safety glass  
 Car door: Mirror ST. ST. framed glass door

### TO -G010

Optional

Car cover: Baking painted steel, acrylic lighting decoration  
 Observation wall: Laminated glass, 6+6mm  
 Decorative ceiling: Baking painted steel frame, light-passing board  
 Car wall: hairline Stainless steel  
 Handrail: Stainless steel flat handrail  
 Floor: PVC

### TO -G011

Optional

Outer decoration: Mirror ST. ST.  
 Ceiling: Mirror ST. ST., acrylic, LED spotlight  
 Observation wall: Laminated safety glass  
 Walls: Mirror ST. ST.  
 Handrail: ST. ST. tube  
 Flooring: Marble  
 Front wall: Laminated safety glass  
 Car door: Mirror ST. ST. framed glass door

# Hospital Elevator

Tenau high-quality medical elevator is developed on basis of deep researches on demands of medical institutions. Our company uses advanced technologies and humanized design to meet demands of doctors and patients for delivering stretchers and medical devices. The elevator is characterized by reliability, stability, accuracy, comfortable experience and energy efficiency. It can meet demands of modernized hospitals, medical centers and sanatoriums.



## Automatic ultraviolet disinfection (optional)

In case of staying in idle status, the elevator will automatically start up ultraviolet disinfection device to eliminate viruses and keep the lift car clean.

## Deferred closing button (optional)

The elevator is equipped with deferred closing button to delay the closing, so as to guarantee personal safety of medical staff and patients while they enter or leave the lift car.

## Safety and reliability

Complete security technology system ensures safe operation of the elevator and provides medical staff and patients with more care.

## Optimized lift car structure

The lift car enables heavy load with a satisfactory depth. It could hold stretchers or even sickbeds.

## EMC (electromagnetic compatibility)

The elevator can resist electromagnetic interference of medical devices to meet demands of medical systems.

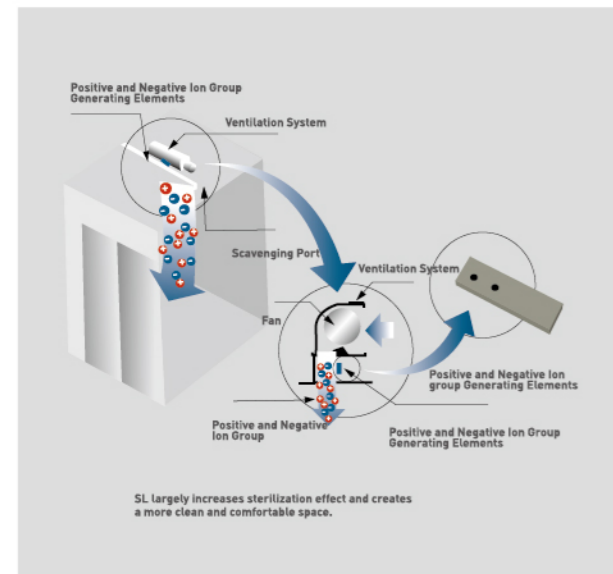

## TO-Y001

Standard

Ceiling: Painted steel, fluorescent lighting, tube lamp (integration)  
 Car wall: Hairline stainless steel  
 Handrail: Double flat stainless steel  
 Floor: PVC

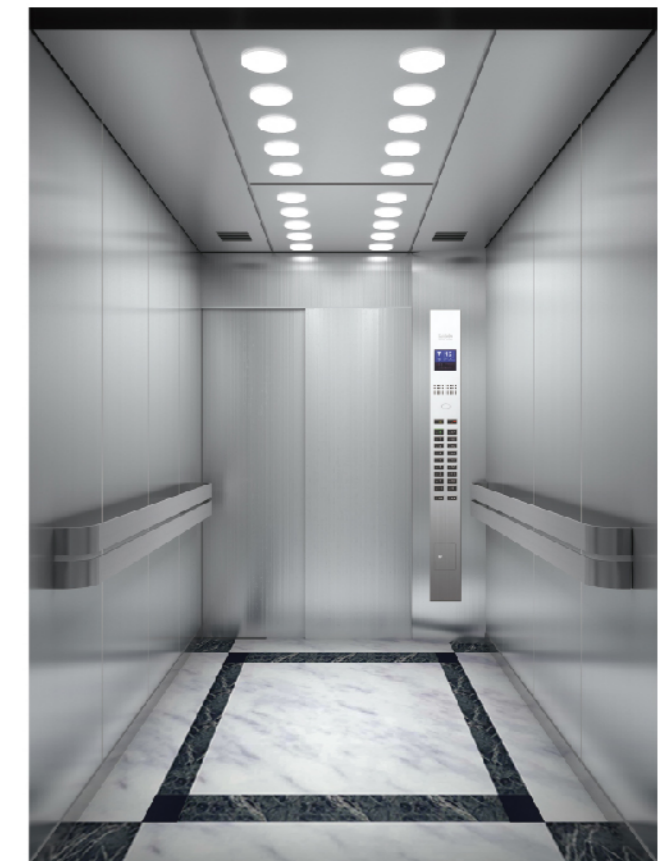

## TO-Y002

Standard

Ceiling: Hairline stainless steel  
 Car wall: Hairline stainless steel  
 Handrail: Double flat stainless steel  
 Floor: PVC

# Cabin Operation Panel

## Standard



**TO-C010**  
(STEP)  
(MONARCH)



**TO-1030A**  
(STEP)

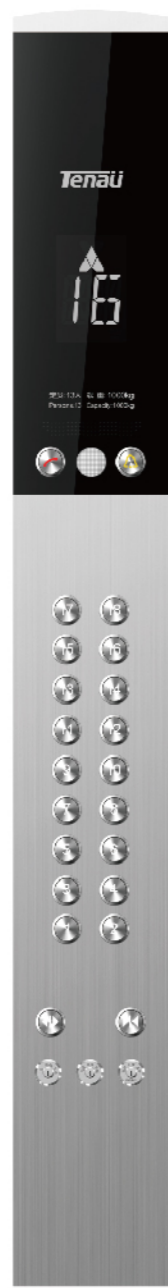

**TO-CEC300**  
(STEP)

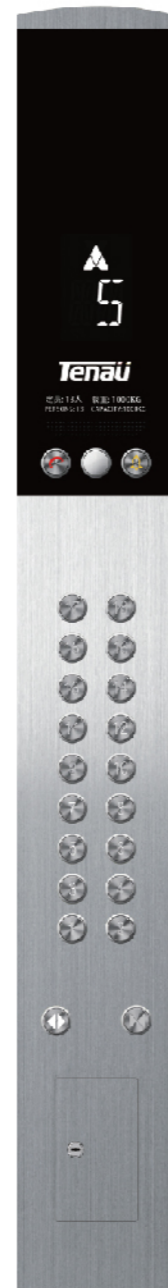

**TO-CEC301**  
(STEP)

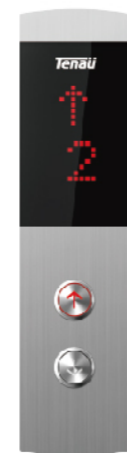

**TO-LSC300**  
(STEP)



**TO-LEC300**  
(STEP)



**TO-CEC260**  
(STEP)



**TO-LSC260**  
(STEP)

## Optional



**TO-C500**  
(MONARCH)



**TO-C500X**  
Wall-mounted  
control box  
(MONARCH)

Display: Dot-matrix display  
Material: Hairline stainless steel  
Parking number: 2-18 F

### Button optional



**TO-AN112**  
Square stainless steel,  
with braille



**TO-AN113**  
Circular stainless steel,  
with braille

# Cabin Operation Panel

## Multimedia display



**TO-LCD01**  
(STEP)  
(MONARCH)



**TO-LCD02**  
(STEP)  
(MONARCH)

Display: Dot-matrix display  
Material: Hairline stainless steel

## Optional



**TO-C600**  
(MONARCH)

Display: Dot-matrix display  
Material: Hairline stainless steel  
Parking number: 2-29 F

Button optional

**TO-AN112**  
Square stainless steel,  
with braille

**TO-AN113**  
Circular stainless steel,  
with braille

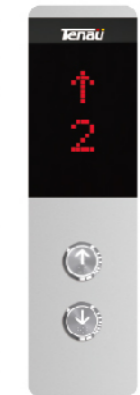

**TO-C610X**  
Wall-mounted  
control box  
(MONARCH)



**TO-C8002**  
(MONARCH)  
Parking number: 2-30 F



**TO-C8004**  
Inserted  
integrated model  
(MONARCH)



**Touch TO-C8012**  
(MONARCH)



**Touch TO-C8011**  
(MONARCH)

## Integrated operation panel



**TO-C700**  
Integrative  
operation panel  
(STEP)  
(MONARCH)



**TO-C8001**  
(MONARCH)  
(Bottomless box)

Panel: Black glass  
Display: Dot-matrix display  
Parking number: 2-30 F



**TO-C8003X**  
(MONARCH)  
(Bottomless box)

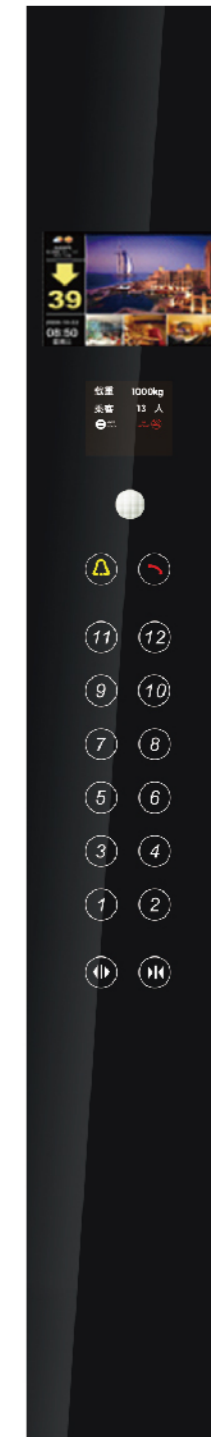

**TO-C090**  
(STEP)  
(MONARCH)  
(Bottom box)

**TO-C090**  
Panel: Black glass  
Mode of display: Multi-media  
Calling button: Touch button  
Skirtboard: LED



**TO-C090X**  
(STEP)  
(MONARCH)  
(Bottom box)



**TO-C090X-2**  
(STEP)  
(MONARCH)  
(Bottom box)

# Optional Decoration

## Hall operation panel (optional)



TO-C8002X



TO-C8002X-2



T09001



TO-C010X



TO-C010X-2



TO-DEC300



TO-LEC300



TO-EH1030A



TO-EHD1030A

## Buttons (Optional)



TO-A101



TO-A102

## Direction light (optional)



TOK212



TOG371



TOK451

## Multimedia (Optional)



Picture display  
7 inch  
8 inch  
10.4 inch

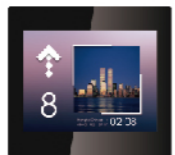

Video display  
8 inch  
10.4 inch  
12.1 inch & 15 inch

## Ceiling



TO-D101

Painted steel plate, four side down lamp



TO-D102

Painted steel, downlight

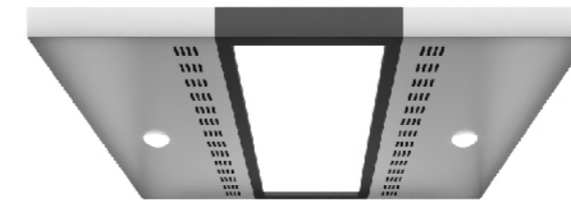

TO-D103

Stainless steel, LED lighting



TO-D106

Mirror stainless steel, LED downlight



TO-D010

Stainless steel mirror board, energy-saving lamps



TO-D040

Stainless steel mirror board, energy-saving lamps



TO-D190

Painted steel, acrylic translucent panel

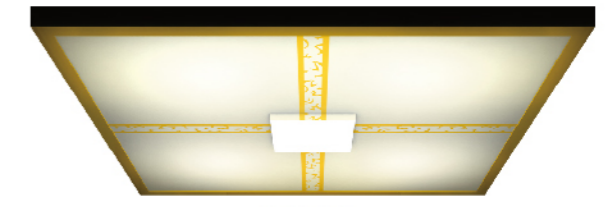

TO-D140

White transparent light board, energy-saving lamps



TO-D200

Image roof, stainless steel, tube lamp with soft illumination



TO-D230

White light-emitting panel, down lamps on both sides

# Optional Decoration

## Handrail (Optional)



TO-F001

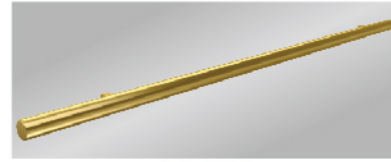

TO-F002

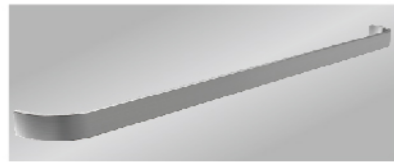

TO-F003

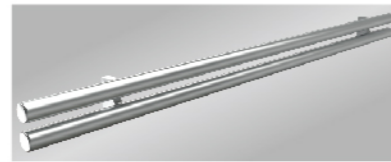

TO-F004

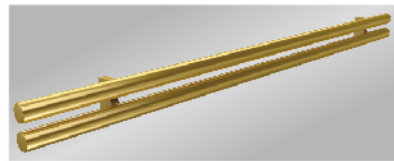

TO-F005



TO-F006

## Floor



TO-B001

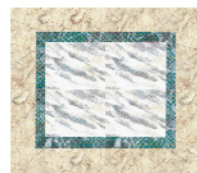

TO-B002

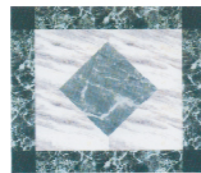

TO-B003

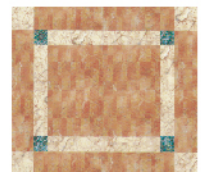

TO-B004



TO-B005



TO-B006

## Landing door series



TO-M010

Landing door: Paint steel  
Jamb: Paint steel

## Color card

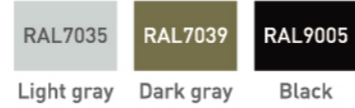

Light gray Dark gray Black



TO-M014

Landing door: Hairline stainless steel  
Jamb: Hairline stainless steel



TO-M011

Landing door: Mirror, etching, hairline  
Jamb: Hairline stainless steel



TO-M012

Landing door: Mirror, etching, hairline  
Jamb: Hairline stainless steel



TO-M013

Landing door: Mirror, etching  
Jamb: Hairline stainless steel



TO-M014

Landing door: Mirror, titanium steel  
Jamb: Hairline stainless steel



TO-M015

Landing door: Mirror, etching, hairline  
Jamb: Hairline stainless steel



TO-M016

Landing door: Mirror, etching, hairline  
Jamb: Hairline stainless steel



TO-M020

Landing door: Mirror, etching, vibration,  
hairline concave in golden  
Jamb: Hairline stainless steel



TO-M021

Landing door: Etching, titanium steel  
Jamb: Hairline stainless steel



TO-M022

Landing door: Glass, hairline stainless steel  
Jamb: Hairline stainless steel

# Function Table

**S-Standard** **O-optional**, **Need to increase Optional**

Travel function	
<b>S</b> VVVF drive	Motor rotating speed can be precisely adjusted to get smooth speed curve in lift start,travel and stop and gain the sound comfort.
<b>S</b> VVVF door operator	Motor rotating speed can be precisely adjusted to get the more gentle and sensitive door machine start/stop.
<b>S</b> Independent running	The lift can not respond to outer calling , but only respond to the command inside the car through the action switch.
<b>S</b> Automatic pass without stop	When the car is crowded with the passengers or the load is close to preset value , the car will automatically pass the calling landing in order to keep maximum travel efficiency.
<b>S</b> Automatically adjustdoor opening time	Door-open time can be automatically adjusted according to the difference between landing calling or car calling.
<b>S</b> Reopen with hall call	In the door shutting process, press reopen with hall call button can restart the door.
<b>S</b> Express door closing	When the lift stops and opens the door, press door-shut button, the door will be closed immediately.
<b>S</b> Car stops and door open	The lift decelerates and levels, the door only opens after the lift comes to a complete stop.
<b>S</b> Car arrival gong	Arrival gong in the car top announces that the passengers arrive.
<b>S</b> Command register cancel	If you press the wrong floor command button in the car,twice continuous pressing of the same button can cancelthe registered command.
<b>O</b> Anti-nuisance	In the light lift load , when three more commands appea, in order to avoid the unnecessary parking , all the registered callings in the car will be cancelled.
<b>O</b> Open the door in advance	When the lift decelerates and enters into door open zone , it automatically opens the door to enhance the travel efficiency.
<b>O</b> Direct parking	It completely accords with distance principle with no crawling in the leveling, It greatly enhances the travel efficiency.
<b>O</b> Group control function	When three or more same model lift groups are controlled in use , the lift g roup can automatically choose the most appropriate response. It avoids the repeated lift parking , reduces the passengers' waiting time and increases the travel efficiency.
<b>O</b> Duplex control	Two sets of same model lifts can unanimously respond the calling signal through the computer dispatch. In this way,it reduces the passengers'waiting time to the greatest extent and enhances the travel efficiency as well.
<b>O</b> On-duty peak service	Within the preset on-duty time , upward transport from the home landing is extremely busy. The lift are continuously dispatched to the home landing in order to satisfy on-duty peak service.
<b>O</b> Off-duty peak service	Within the preset off-duty period, the lifts are continuously dispatched to top f1oor in order to satisfy off-duty peak service.
<b>O</b> Door open time extending	Press special button in the car,the lift door keeps open for certain period of time.
Man-machine interface	
<b>S</b> Micro-touch button for car call and hall call	Novel micro-touch button is used for operation panel command button in the car and landing calling button.
<b>S</b> Floor and direction indicator inside car	The car shows the lift floor location and current travel direction.
<b>S</b> Floor and direction indicator in hall	The landing shows the lift floor loction and current travel direction.
<b>O</b> Voice announcer	When the lift normally arrives, voice announcer informs the passengers about the relevant information.
<b>O</b> Car assistant operation box	It is used in the large loading weight lifts or the lifts with crowded passengers so that more and more passengers can use the car.
<b>O</b> Operation box for the handicapped	It is convenient for the wheelchair passengers and those who have vision problems.
<b>O</b> Intelligent calling service	The car command or hoist-way calling can be locked or connected through special Intelligent Input.
<b>O</b> IC card control function	All[partial]landings can only input car commands through IC Card after the authorization.

Monitor function	
<b>O</b> Remote monitor	The lift long-distance monitor and control can be fulfilled through modem and telephone . It is convenient for the factories and service units to timely know the travel conditions of every lift and promptly take the corresponding measures.
<b>O</b> Remote control	The lift can have independent travel according to the specific requirements through operation monitor screen (optional).
<b>O</b> Camera function in the car	The camera is installed in the car to monitor the car conditions.

Safety function	
<b>S</b> Light curtains protection	In the door open and shut period , infrared light that covers the whole door height is used to probe the door protection device of both the passengers and objects.
<b>S</b> Designated stop	If the lift can not open the door in the destination floor out of some reason , the lift will close the door and travelto the next designated floor.
<b>S</b> Overload holding stop	When the car is overload , the buzzer rings and stops the lift in the same floor.
<b>S</b> Anti-stall timer protection	The lift stops operation due to slippery traction wire rope.
<b>S</b> Start protection control	If the lift does not leave door zone within the designated time after it gets started,it will stop the operation.
<b>S</b> Inspection operation	When the lift enters into inspection operation , the car travels at inching running.
<b>S</b> Fault self-diagnosis	The controller can record 62 latest troubles so as to quickly remove the trouble and restore the lift operation.
<b>S</b> Repeated door closing	If the lift can not close the door dueto certain obstacle or interference,the lift will reopen or re-shut the door until sundries are eliminated.
<b>S</b> Up/down over-run and final limit protection	The device can effectively prevent from the lift's surging to the trouble and restore the lift operation.
<b>S</b> Down over-speed protection device	When the lift down 1.2 time higher than the rated speed, this device will automatically cut off control mains, stop the motor running so as to stop lift down at over-speed. If the lift continues to down at over-speed , and the speed is 1.4 time higher than rated speed , safety tongs act to force the lift stop in order to ensure the safety.
<b>S</b> Upward over-speed protection device	When the lift up speed is 1.2 times higher than rated speed , the device will automatically decelerate or brake the lift.
<b>S</b> Elevator cab prevents accidental movement	When the elevator is in the open state , if there is accidental movement , the elevator cab can present the movement.

Emergency function	
<b>S</b> Emergency car lighting	Emergency car lighting automatically activated once power failure.
<b>S</b> Inching running	When the lift enters into emergency electric operation , the car travels at low speed inching running.
<b>S</b> Five way intercom	Communication amid car car top, lift machine room , well pit and rescue duty room through walkie-talkie.
<b>S</b> Bell	In emergency conditions , if bell button above car operation panel is continuously pressed, electric bell rings on top of the car.
<b>S</b> Fire emergency return	If you start key switch in main landing or monitor screen , all the callings will be cancelled. The lift directly and immediately drives to the designated rescue landing and automatically opens the door.
<b>O</b> Leveling when power failure	In normal power failure, the chargeable battery supplies the lift power. The lift drives to the nearest landing.

Energy-saving function	
<b>S</b> Car ventilation, light automatic shut off	If there is no calling or command signal within the stipulated time , the car fan and lighting will be automatically closed in order to save the energy.
<b>S</b> Remote shut-off	The lift can be called to main landing(after finishing the service)through the key switch and automatically exists the service.

# Machine Room Passenger Elevator Construction Parameter

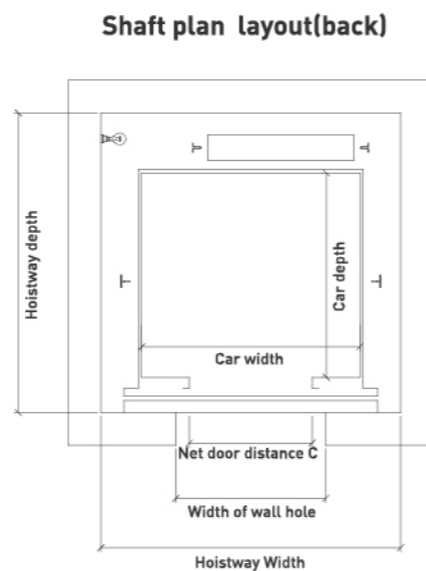
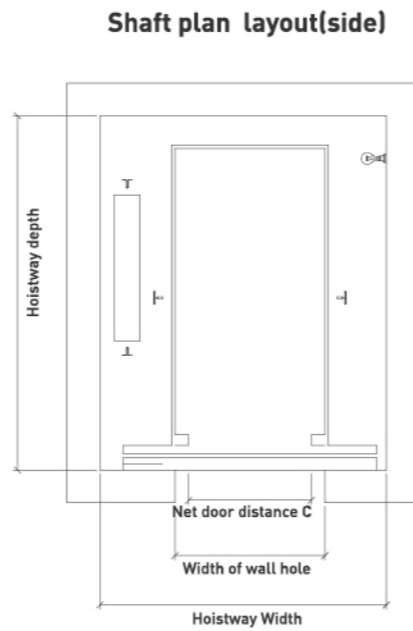
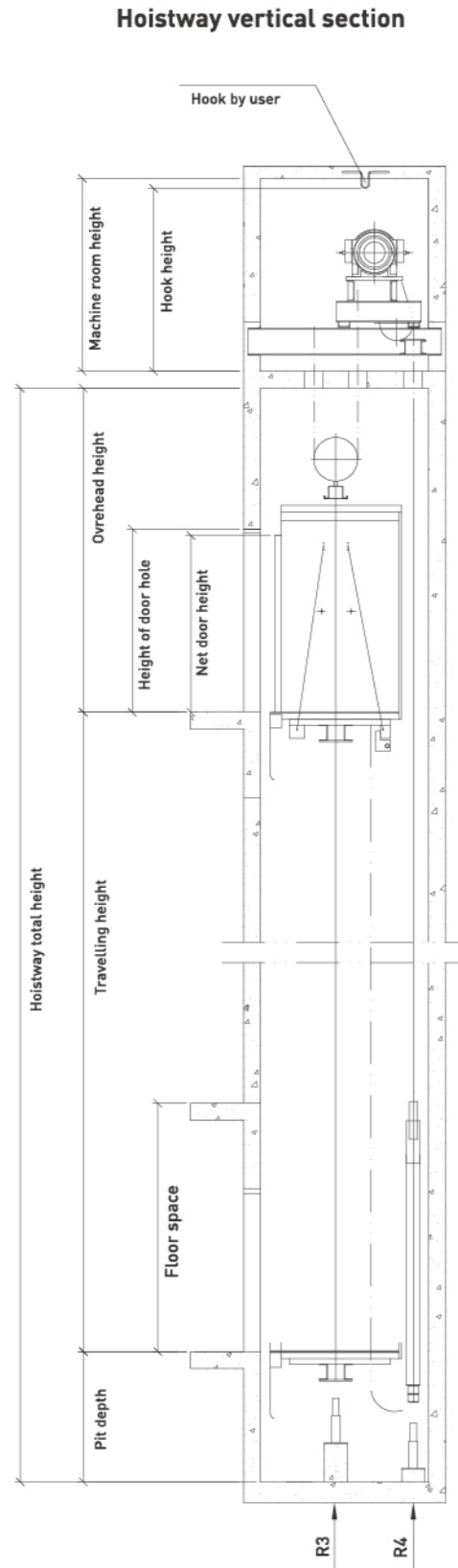

Back machine room passenger elevator parameters

Load(kg)	Speed (m/s)	Car dimension(mm)	Door-opening size(mm)	Hoistway size(mm)	Overhead height ( OH )	Pit depth ( PP )
		Inner size AXB	Net door-opening	Width x depth		
630	1.0	1400X1100	800	1950X1750	4000	1200
	1.5				4100	1300
	1.75				4200	1400
	2.0				4500	1500
800	1.0	1400X1350	800	1950X2000	4000	1200
	1.5				4100	1300
	1.75				4200	1400
	2.0				4500	1500
	2.5			2000X2050	5000	2000
1000	1.0	1600X1500	900	2150X2150	4000	1200
	1.5				4100	1300
	1.75				4200	1400
	2.0				4500	1500
	2.5			2200X2200	5000	2000
1250	1.0	1800X1550	1100	2350X2200	4000	1200
	1.5				4100	1300
	1.75				4200	1400
	2.0				4500	1500
	2.5			2400X2250	5000	2000
1350	1.0	1900X1600	1100	2450X2300	4000	1200
	1.5				4100	1300
	1.75				4200	1400
	2.0				4500	1500
	2.5			2500X2350	5000	2000
1600	1.0	1950X1700	1100	2500X2400	4000	1200
	1.5				4100	1300
	1.75				4200	1400
	2.0				4500	1500
	2.5			2550X2450	5000	2000

Side machine room passenger elevator parameters

Load(kg)	Speed (m/s)	Car dimension(mm)	Door-opening size(mm)	Hoistway size(mm)	Overhead height ( OH )	Pit depth ( PP )
		Inner size AXB	Net door-opening	Width x depth		
630	1.0	1400X1100	800	2200X1700	3800	1200
	1.5				3900	1300
	1.75				4000	1400
	2.0				4300	1500
800	1.0	1400X1350	800	2200X1800	3800	1200
	1.5				3900	1300
	1.75				4000	1400
	2.0				4300	1500
	2.5			2250X1850	5000	2000
1000	1.0	1600X1500	900	2400X1950	3800	1200
	1.5				3900	1300
	1.75				4000	1400
	2.0				4300	1500
	2.5			2450X2000	5000	2000
1000 Stretcher elevator	1.0	1100X2100	900	2100X2500	3800	1200
	1.5				3900	1300
	1.75				4000	1400
	2.0				4300	1500
	2.5			2150X2550	5000	2000
1250	1.0	1800X1550	1100	2600X2050	3800	1200
	1.5				3900	1300
	1.75				4000	1400
	2.0				4300	1500
	2.5			2650X2100	5000	2000
1350	1.0	1900X1600	1100	2750X2100	3800	1200
	1.5				3900	1300
	1.75				4000	1400
	2.0				4300	1500
	2.5			2800X2150	5000	2000
1600	1.0	1950X1700	1100	2800X2200	3800	1200
	1.5				3900	1300
	1.75				4000	1400
	2.0				4300	1500
	2.5			2850X2250	5000	2000

The above civil construction parameter is for reference. Civil construction is subject to the formal civil construction diagrams.

# Machine Roomless Passenger Elevator Construction Parameter

Hoistway vertical section

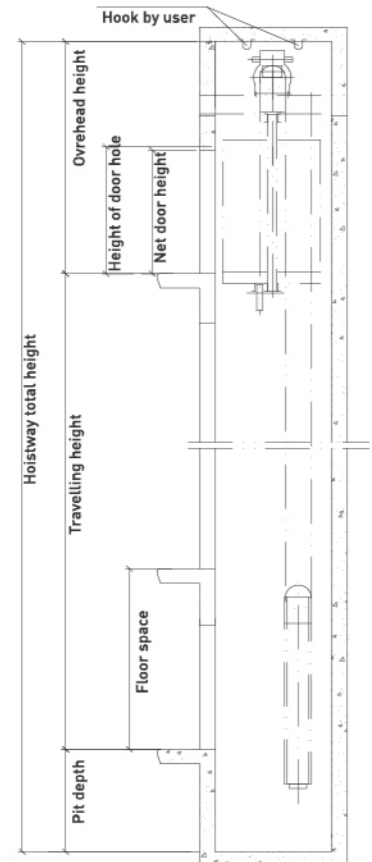

Shaft plan layout

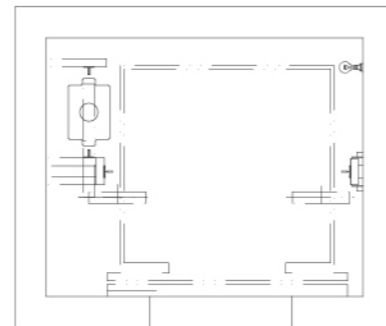

Machine roomless passenger elevator parameters

Load(kg)	Speed (m/s)	Car dimension(mm)	Door-opening size(mm)	Hoistway size(mm)	Overhead height ( OH )	Pit depth ( PP )
		Inner size AXB	Net door-opening	Width x depth		
630	1.0	1400X1100	800	2250X1750	3800	1300
	1.5				3900	1400
	1.75				4000	1500
	2.0				4300	1600
800	1.0	1400X1350	800	2250X1800	3800	1300
	1.5				3900	1400
	1.75				4000	1500
	2.0				4300	1600
1000	1.0	1600X1500	900	2450X1900	3800	1300
	1.5				3900	1400
	1.75				4000	1500
	2.0				4300	1600
1250	1.0	1800X1550	1100	2700X2000	4000	1300
	1.5				4100	1400
	1.75				4200	1500
	2.0				4300	1600
1350	1.0	1900X1600	1100	2800X2100	4000	1300
	1.5				4100	1400
	1.75				4200	1500
	2.0				4300	1600
1600	1.0	1950X1700	1100	2850X2200	4000	1300
	1.5				4100	1400
	1.75				4200	1500
	2.0				4500	1600
1600 Hospital elevator	1.0	1400X2400	1100	2550X2900	4200	1300
	1.5				4300	1400
	1.75				4400	1500
	2.0				4500	1600

The above civil construction parameter is for reference. Civil construction is subject to the formal civil construction diagrams.

# Hospital Elevator Construction Parameter

Hoistway vertical section

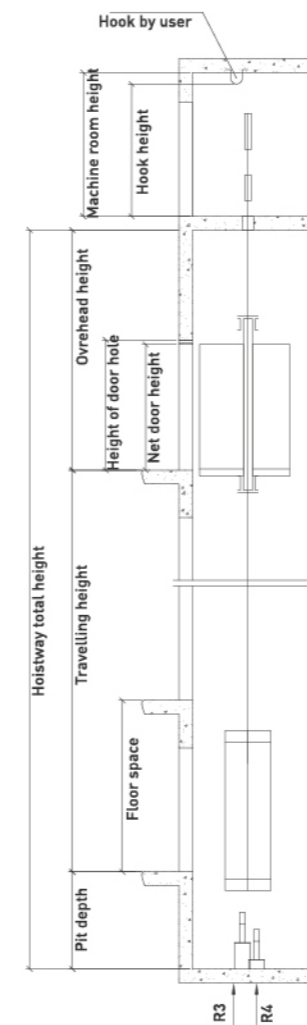

Shaft plan layout

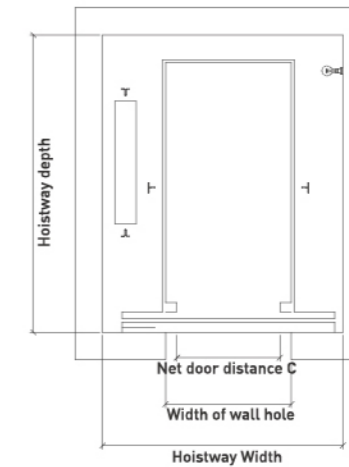

Hospital elevator parameters

Load(kg)	Speed (m/s)	Car dimension(mm)	Door-opening size(mm)	Hoistway size(mm)	Overhead height ( OH )	Pit depth ( PP )
		Inner size AXB	Net door-opening	Width x depth		
1600	1.0	1400X2400	1100	2500X2900	4000	1300
	1.5				4100	1400
	1.75				4200	1500
	2.0				4300	1600
2000	1.0	1500X2700	1300	2550X2950	5000	2000
	1.5			2600X3200	4000	1300
	1.75				4100	1400
	2.0				4200	1500
2000	2.0	2650X3250	1300	2650X3250	4300	1600
	2.5				5000	2000

The above civil construction parameter is for reference. Civil construction is subject to the formal civil construction diagrams.

# Machine Room Panoramic Elevator Construction Parameter

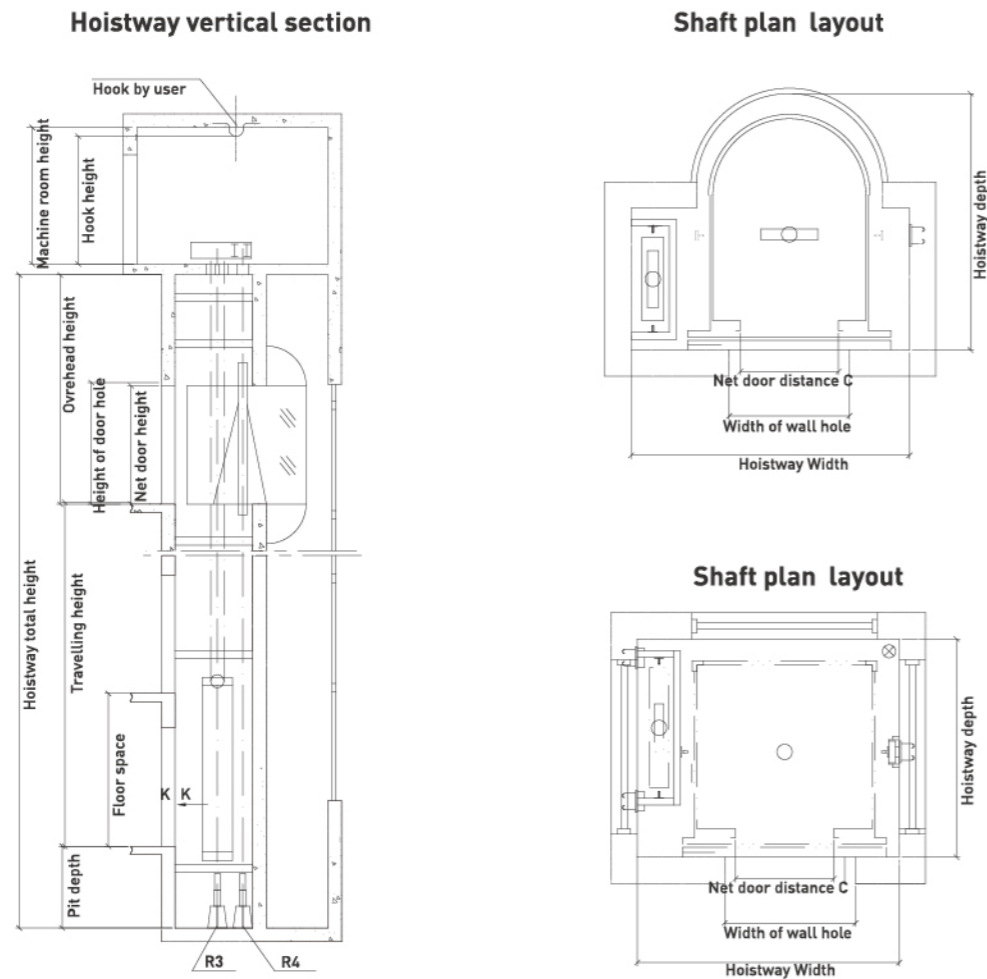

# Machine Roomless Panoramic Elevator Construction Parameter

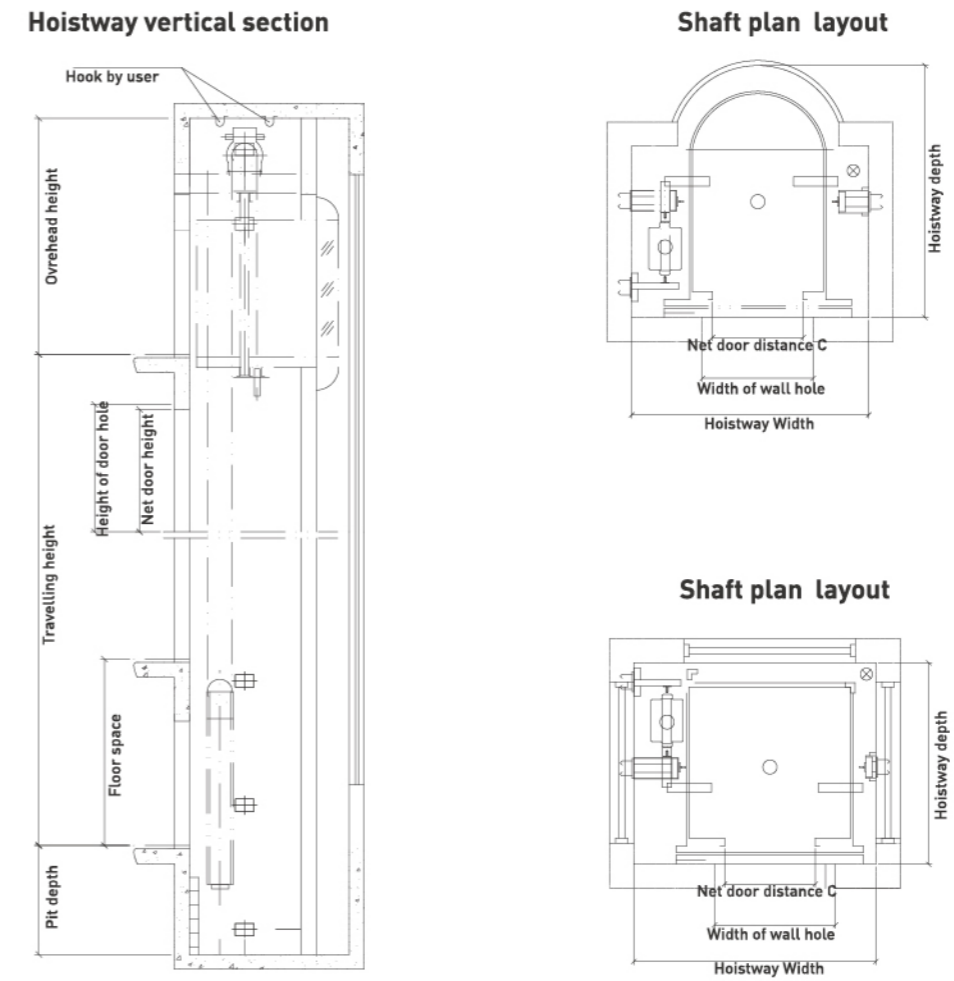

Machine room panoramic elevator parameters

Load(kg)	Speed (m/s)	Car dimension(mm)		Door-opening size(mm)	Hoistway size(mm)		Overhead height (OH)	Pit depth (PP)
		Inner size AXB		Net door-opening	Width x depth			
		Square	Round		Square	Round		
630	1.0	1400X1100	1300X1700	800	2200X1700	2150X2250	4000	1500
	1.5						4100	1600
	1.75						4200	1700
	2.0						4300	1800
800	1.0	1400X1350	1300X1700	800	2200X1800	2350X2250	4000	1500
	1.5						4100	1600
	1.75						4200	1700
	2.0						4300	1800
1000	1.0	1600X1500	1400X1850	900	2400X2000	2450X2350	4000	1500
	1.5						4100	1600
	1.75						4200	1700
	2.0						4300	1800
1250	1.0	1800X1550	1400X2150	900/1100	2600X2100	2350X2650	4200	1500
	1.5						4300	1600
	1.75						4400	1700
	2.0						4500	1800
1600	1.0	1950X1700	1500X2300	1000/1100	2750X2200	2500X2850	4200	1500
	1.5						4300	1600
	1.75						4400	1700
	2.0						4500	1800

The above civil construction parameter is for reference. Civil construction is subject to the formal civil construction diagrams.

Machine roomless panoramic elevator parameters

Load(kg)	Speed (m/s)	Car dimension(mm)		Door-opening size(mm)	Hoistway size(mm)		Overhead height (OH)	Pit depth (PP)
		Inner size AXB		Net door-opening	Width x depth			
		Square	Round		Square	Round		
630	1.0	1400X1100	No	800	2250X1700	No	4000	1500
	1.5						4100	1600
	1.75						4200	1700
	2.0						4300	1800
800	1.0	1400X1350	1300X1700	800	2250X1800	2150X2500	4000	1500
	1.5						4100	1600
	1.75						4200	1700
	2.0						4300	1800
1000	1.0	1600X1500	1400X1850	900	2450X2000	2350X2500	4000	1500
	1.5						4100	1600
	1.75						4200	1700
	2.0						4300	1800
1250	1.0	1800X1550	1400X2150	900/1100	2650X2100	2500X2650	4200	1500
	1.5						4300	1600
	1.75						4400	1700
	2.0						4500	1800
1600	1.0	1950X1700	1500X2300	1000/1100	2850X2200	2600X2850	4200	1500
	1.5						4300	1600
	1.75						4400	1700
	2.0						4500	1800

The above civil construction parameter is for reference. Civil construction is subject to the formal civil construction diagrams.

## Spacious Space Taste Leisurely Life

**Open space for your luxury villa  
To highlight your identity, even the lift car  
of elevator is no exception.**

With compact design adopted for Tenau villa elevator, it saves the using area of well by 15%-20% and could provide larger size of lift car in the same well. The maximum net height of lift car can reach 2200mm (roof height: 3m), which can bring you open space experience and make you go in and out more easily.

It can save the using area of well at least by 15%

15%

The roof height can reach 3m

3M



## Green and Noiseless Design Gives You Healthy Life

Equivalent to that released by a big tree with the height of 5m

5M

Filters PM2.5 to make lift car filled with exceptional fresh air

PM2.5

### 8 million- negative oxygen ion fan (optional)

The anion it releases is equivalent to that released by a big tree with the height of 5m. In the meantime, it can sterilize, absorb methanol, remove peculiar smell & second-hand smoke and filter PM2.5 to make lift car filled with exceptional fresh air.

### 8 million negative oxygen ion fan

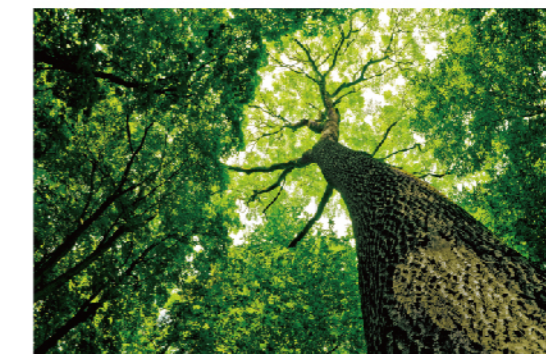

The application of a series of intelligent technologies to Tenau villa not only brings you comfort but also health.

# Villa Cabin Decoration

## Warm and Elegant



### TO-V001

Optional

Ceiling: wooden modelling, gold foil, lamp belt and LED tube lamp  
 Side wall: craft wooden facing, wallpaper and craft glass  
 Rear wall: craft wooden facing, car edge mirror and wallpaper  
 Handrail: craft handrail  
 Floor: marble pattern



## Warm and Elegant



### TO-V002

Optional

Ceiling: rose gold mirror stainless steel, gold foil and LED tube lamp  
 Side wall: craft wooden facing and rose gold mirror stainless steel etching  
 Rear wall: craft wooden facing and rose gold mirror stainless steel etching  
 Handrail: craft handrail  
 Floor: marble pattern



## Minimalist Style



### TO-V043

Optional

Ceiling: hairline stainless steel, acrylic light decoration, down light  
 Car wall: hairline stainless steel, mirror stainless steel  
 Handrail: stainless steel tube  
 Floor: PVC pattern



## Modern Style



### TO-V010

Optional

Ceiling: mirror stainless steel, LED downlight  
 Car wall: wood veneer, mirror stainless steel  
 Floor: PVC



## Simple



### TO-V003

Optional

Ceiling: metal stoving varnish modeling, LED tube lamp  
 Side wall: color grain steel plate, white stoving varnish steel plate and brushed stainless steel trim strip  
 Rear wall: color grain steel plate, white stoving varnish steel plate  
 Floor: PVC pattern



## Enjoyable

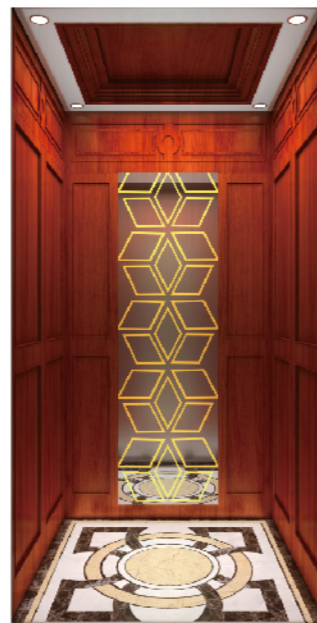

### TO-V040

Optional

Ceiling: painted steel frame, middle mirror stainless steel, surrounded by downlight lighting  
 Side wall: rosewood veneer  
 Rear wall: both sides of the rosewood, the middle mirror titanium etching stainless steel  
 Floor: marble pattern



## Golden Age



### TO-V019

Optional

Ceiling: titanium mirror, cross-flow fan, LED floodlight  
 Side wall: titanium mirror etching, marble  
 Rear wall: titanium mirror, marble  
 Floor: marble pattern



## Simple



### TO-V004

Optional

Ceiling: metal stoving varnish modeling, mirror stainless steel and LED tube lamp  
 Side wall: color grain steel plate  
 Rear wall: marble pad pasting, black titanium mirror stainless steel  
 Floor: PVC pattern



# Villa Decoration

## Car operation panel



## Handrail



## Ceiling

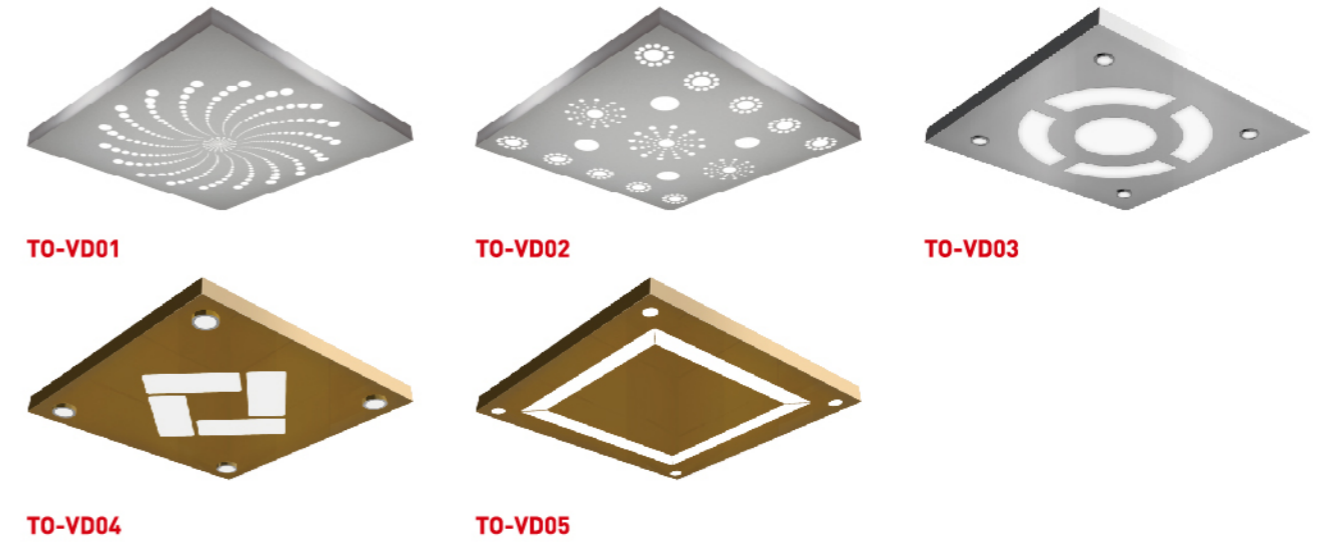

## Landing door series



## Hoistway frame

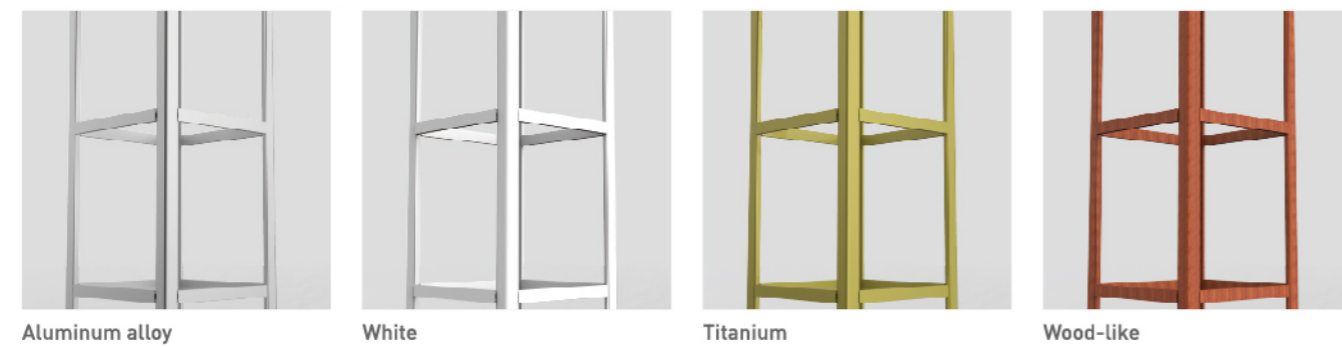

## Floor



# Function Table

**S** Standard Function    **O** Optional Function

## General Protection

<b>S</b> Closing time protection	<b>S</b> Protection against reverse travel
<b>S</b> Emergency lighting in the car	<b>S</b> Prevent slipping protection
<b>S</b> Overload warning (Caution light and buzzer)	<b>S</b> Safety circuit protection
<b>S</b> The screen door protection device	<b>S</b> Limit protection
<b>S</b> Car roof and control cabinet emergency electric operation	<b>S</b> Upper and lower limit protection device
<b>S</b> Fault automatic diagnosis	<b>S</b> Door interlock protection
<b>S</b> Alarm bell	<b>S</b> Operation contactor protection
<b>S</b> Hitting the bottom buffer device	<b>S</b> Brake detection and protection
<b>S</b> Outside door zone without opening door	<b>S</b> Manual brake release rescue
<b>S</b> Wave detection of grid voltage	<b>S</b> Machine room door switch
<b>S</b> Contactor feedback detection	<b>S</b> Driven equipment overheating protection (OHT)
<b>S</b> Relay detection protection	<b>S</b> Electric brake
<b>S</b> Speed feedback detection	<b>O</b> Automatic rescue device
<b>S</b> Fault low-speed self-rescue	<b>S</b> Emergency power supply device operation
<b>S</b> Hb button embedded self-diagnosis	

## Information Display

<b>S</b> Hall and car digital position indicator	<b>S</b> Running number display
<b>S</b> Hall and car call/register	<b>S</b> Floor display character arbitrary setting
<b>S</b> Hall and car running direction display	

## Steady Running

<b>S</b> Return to base station without call	<b>S</b> Pre-torque output
<b>S</b> Full collective control	<b>S</b> Upon elevator floor setting
<b>S</b> Independent service	<b>S</b> Hoistway self-learning
<b>S</b> Full-load direct running (LNS)	<b>S</b> End station for speed and floor number correction
<b>S</b> Automatic door switch	<b>S</b> Parking

## Passenger Comfortability

<b>S</b> Hall and car door setting time	<b>S</b> Bypassed stop setting
<b>S</b> Open and close button	<b>S</b> Input port evaluation
<b>S</b> Automatic ventilation and lighting of automatic control in car	<b>S</b> Manually selected floor
<b>S</b> Hb calls door opening	<b>S</b> Cancellation of wrong landing
<b>S</b> Repeated closing door	<b>O</b> Voice announcement
	<b>O</b> Liquid display

## Security Monitoring

<b>O</b> CCTV cable (From car to machine room)	<b>O</b> BA interface (Dry contact)
<b>S</b> Elevator remote control	<b>O</b> Community monitoring panel
<b>O</b> Card reader	<b>O</b> Community computer monitoring

# Construction Parameter Villa Elevator

## Gantry type villa elevator

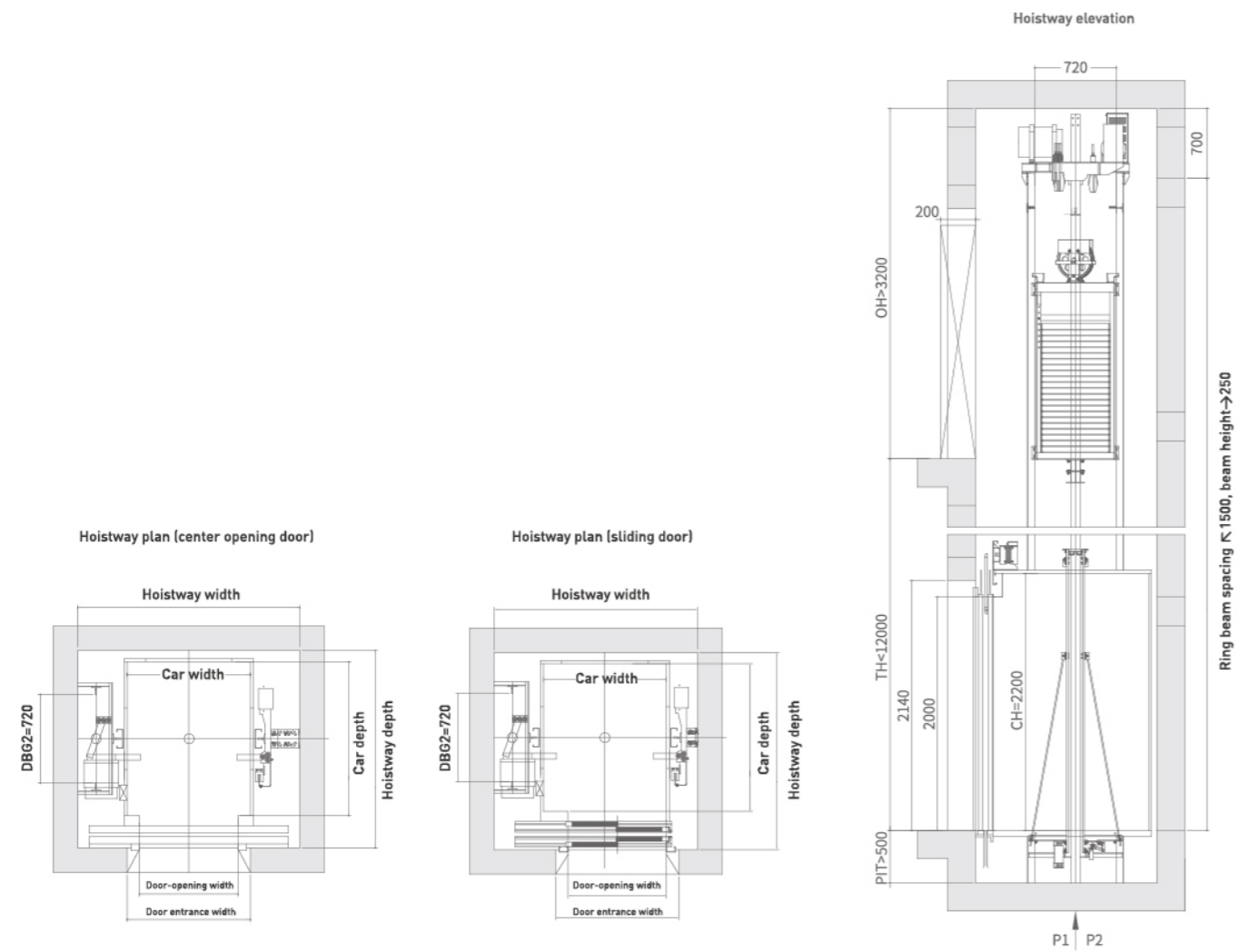

### Gantry type (center opening door)

Load	Speed	Car net size	Door opening width	Door width	Hoistway net size	Top height	Pit depth
250	0.4	800x1250	700 Center opening	900	1600x1600	3200	500
320	0.4	900x1250	700 Center opening	900	1650x1600	3200	500
400	0.4	1000x1250	800 Center opening	1000	1800x1600	3200	500

### Gantry type (sliding door)

Load	Speed	Car net size	Door opening width	Door width	Hoistway net size	Top height	Pit depth
250	0.4	800x1200	700 Side opening	900	1450x1600	3200	500
320	0.4	900x1200	800 Side opening	1000	1550x1600	3200	500
400	0.4	1000x1200	800 Side opening	1000	1650x1600	3200	500

Note: The above civil construction parameter is for reference. Civil construction is subject to the formal civil construction diagrams.

## Rucksack type villa elevator

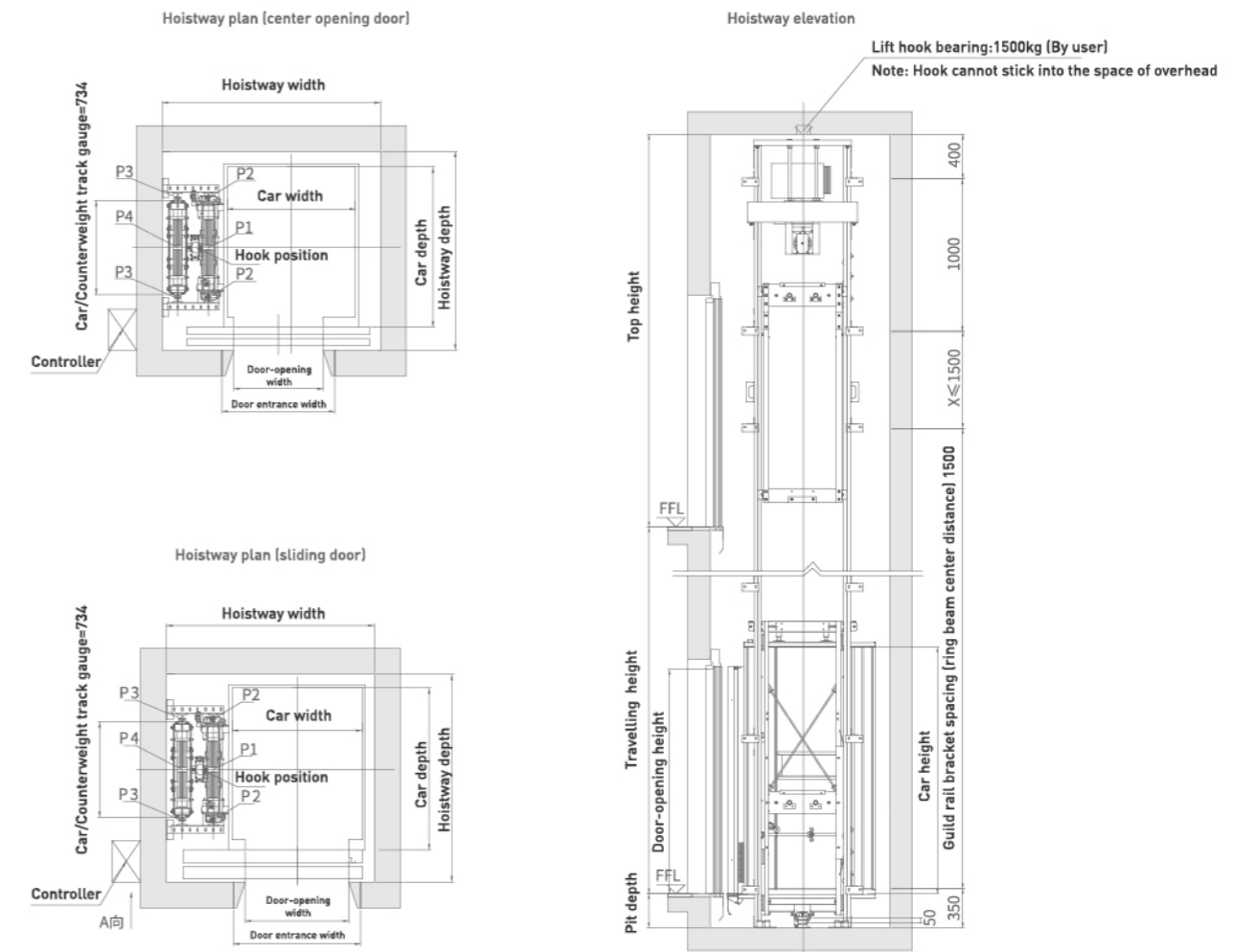

### Rucksack type (center opening door)

Load	Speed	Car net size	Door opening width	Door width	Hoistway net size	Top height	Pit depth
250	0.4	800x1250	700 Center opening	900	1600x1600	3200	350
320	0.4	900x1250	700 Center opening	900	1650x1600	3200	350
400	0.4	1000x1250	800 Center opening	1000	1800x1600	3200	350

### Rucksack type (sliding door)

Load	Speed	Car net size	Door opening width	Door width	Hoistway net size	Top height	Pit depth
250	0.4	800x1200	700 Side opening	900	1450x1600	3200	350
320	0.4	900x1200	800 Side opening	1000	1550x1600	3200	350
400	0.4	1000x1200	800 Side opening	1000	1650x1600	3200	350

Note: The above civil construction parameter is for reference. Civil construction is subject to the formal civil construction diagrams.

# Freight Elevator



This elevator is specifically designed for the transportation of cargoes, with many wide door opening modes and spacious yet sturdy car, suitable for the transportation of large cargoes and ensuring the safety when passengers and cargoes both present in the car. Technically, advanced CPU control is applied, realizing contact free control to elevate the performance of the elevator, making it the best choice for cargo transportation in factories, warehouses and malls, etc.

## Consider practicality

Considering the size of the cargoes, the designing for the door of the car adopts multiple methods to open, so as to ensure the width of the door opening is the same as that of the car, making cargoes move freely in and out.

## Subtle processing

VVVF technology ensures constant torque and, with a sturdy car, the elevator can keep constant operation under all circumstances and precise floor leveling.

## Proven safety

Based upon standardized safety device, the slippery resistance as well as the door machine's safety configuration is improved, which ensures the precise leveling for cargo transportation.

## The multiple door opening modes

In order to satisfy different entry / exit requirements from vast users, TENAU freight elevator offers four door opening modes of side opening, central opening double-folded door, one-way door opening, opposite door opening. It can flexibly match with the factory, warehouse, department store, shopping center, housing property management center etc.

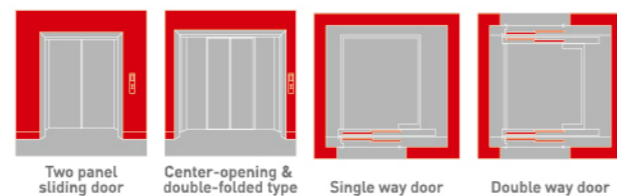

# Car Elevator



In the modern city, there are more and more cars. To solve the difficulty of parking, TENAU uses its mature elevator technology to make for cars a hindrance-free transportation, vertically through a design, that considers the performance and size of various cars.

## Large load capacity

Large area of the car elevator ensures a normal load capacity of over 3 tons, capable of handling various cars.

## Convenient door opening design

Front and rear door opening are available, making it easy for cars to move in and out.

Rated load

> 3t

Save construction area

80%

## Reliable safety device

Safety device is mounted on the car ground of the elevator, which alerts the drivers on real time basis to ensure safe operation.

# Decoration of Freight Elevator & Car Elevator



## TO-J21H

Standard

Ceiling: Painted steel (optional color)  
 Car wall: Painted steel (optional color)  
 Car door: Painted steel (optional color)  
 Skirtboard: Fluorescent lamp  
 Floor: Riffled plate



## TO-J22H

Optional

Ceiling: Hairline stainless steel  
 Car wall: Hairline stainless steel  
 Car door: Hairline stainless steel  
 Skirtboard: Fluorescent lamp  
 Floor: Riffled plate

## Ceiling



TO-D100



TO-D110



TO-D120



TO-C100



TO-C100X

## Car operation panel

Panel: Hairline stainless steel  
 Display board: Plastic board (dark blue)  
 Mode of display: Digital LED matrix display  
 Calling button: Micro-buttons/framed mirrors, sanded stainless steel for the panel  
 Responding light: LED

## Landing door series



TO-M070  
Standard



TO-M080  
Standard

## Optional color cards

RAL7035  
Light gray

RAL1015  
Creamcolored

RAL6027  
Light green

RAL6019  
Indigo Green

# Function Table

Control function	Information function	Safety function	Comfortable function
<b>S</b> Well and floor distance self-tuning	<b>S</b> Full collective control	<b>S</b> Light curtain protection	<b>S</b> Emergency car lighting
<b>S</b> Power on re-leveling	<b>S</b> Full-load bypass	<b>S</b> Overload holding stop	<b>S</b> Car ventilation light automatically shut off
<b>S</b> Micro-touch button for car	<b>S</b> Main floor shut off	<b>S</b> Terminal forced slow-down protection	<b>S</b> Repeated door closing
<b>S</b> Start protection control	<b>S</b> Self diagnosis of breakdown	<b>S</b> Up/down overrun and final limit protection	<b>S</b> Reopen with hall call
<b>O</b> Car arrival chime	<b>S</b> Five-way communication	<b>S</b> Down over speed protection	<b>S</b> Express door closing
<b>S</b> VVVF drive	<b>S</b> Car's Bell	<b>S</b> Up over speed protection	<b>S</b> Car stop and door open
<b>S</b> VVVF drive for door operator	<b>S</b> Floor and direction indicator in the car	<b>S</b> Safely stop	<b>O</b> Door opening time extending
<b>O</b> The second car operation panel	<b>S</b> Floor and direction indicator at hall	<b>S</b> Inching operation	<b>S</b> Door close delay
<b>S</b> Automatic adjustment of door open holding time	<b>O</b> Voice announcement	<b>S</b> Inspection operation	
<b>S</b> Car call cancel	<b>O</b> Traffic dispatch	<b>O</b> Power failure emergency leveling device	
<b>S</b> Automatic running	<b>O</b> IC card control	<b>S</b> Anti-nuisance	
<b>S</b> Attendant running	<b>O</b> Traction machine monitor	<b>S</b> Fire emergency return	
<b>S</b> Duplex control function		<b>S</b> Auto-landing with fault	
<b>S</b> Double door control		<b>S</b> Safety circuit protection	
<b>O</b> IC card control		<b>S</b> Door interlock protection	
		<b>S</b> Main contactor protection	
		<b>S</b> Brake detecting protection	

**S** Standard Function **O** Optional Function

Remark: Please refer to TENAU technical documents and contact our TENAU sales person for details.

# Freight Elevator Construction Parameter

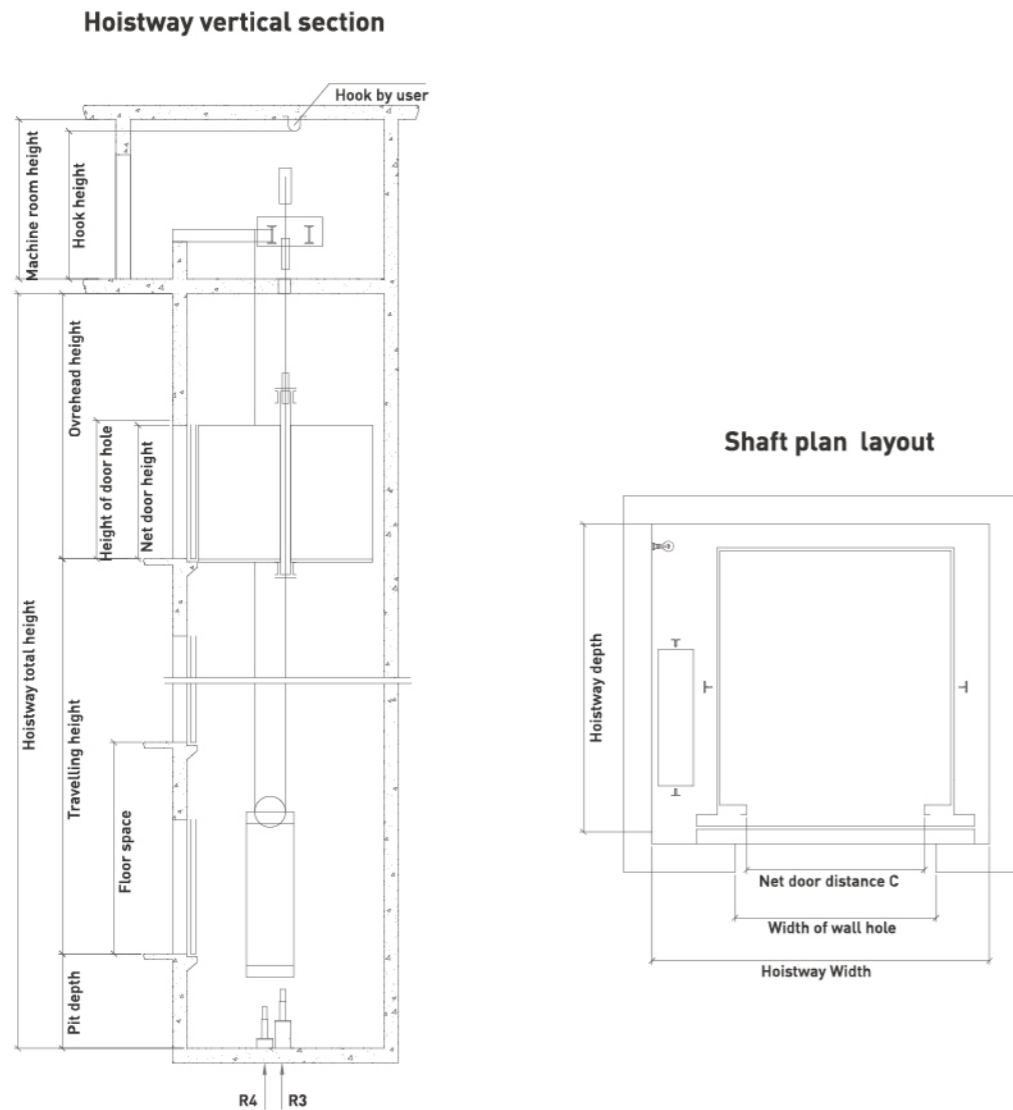

# Machine Roomless Freight Elevator Construction Parameter

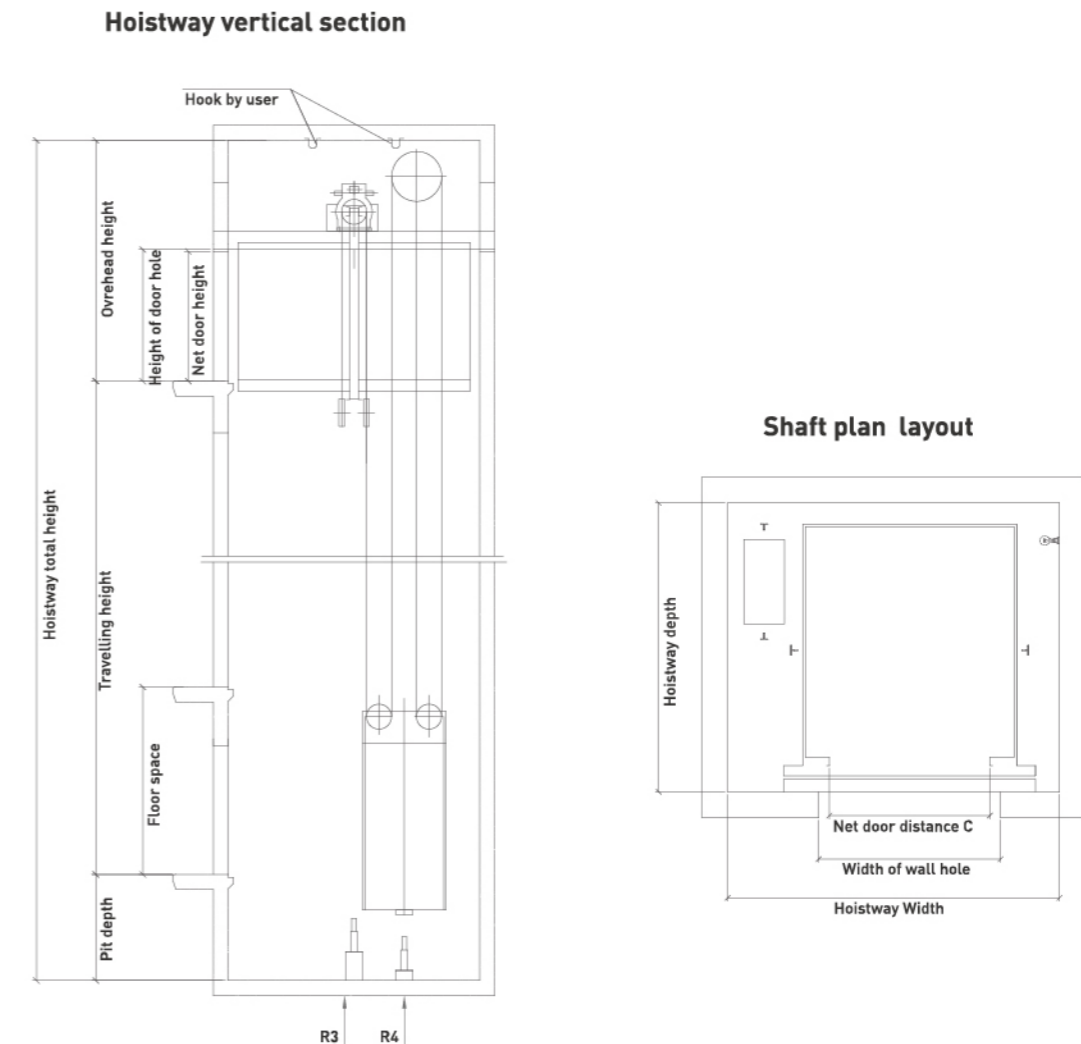

Freight elevator parameters

Load(kg)	Speed (m/s)	Car dimension(mm)	Door-opening size(mm)		Hoistway size(mm)	Machine room size	Overhead height (OH)	Pit depth (PP)
		Inner size AXB	Net door-opening	Net door height	XxY	SxT		
1000	0.5	1450x1600	1100	2200	2300x2200	3000x3000	4000	1200
2000	0.5	1950x2150	1500	2200	2850x2700	3500x4000	4200	1300
	1.0							
3000	0.5	2000x2900	2000	2200	3450x3400	4000x4000	4300	1400
	1.0							
5000	0.5	2400x3600	2400	2400	4000x4100	4200x5000	4400	1500
	1.0							
10000	0.5	3200x5000	2600	2400	4700x5500	4700x5500	4600	1700

Machine roomless freight elevator parameters

Load(kg)	Speed(m/s)	Car dimension(mm)	Door-opening size(mm)		Hoistway size(mm)	Overhead height (OH)	Pit depth (PP)
		Inner size AXB	Net door-opening	Net door height	XxY		
1600	0.5	1600x2150	1400	2200	2700x2600	4300	1500
	1.0						
2000	0.5	1950x2150	1500	2200	3200x2800	4400	1500
	1.0						
3000	0.5	2000x2900	2000	2200	3600x3400	4500	1500
	1.0						

# Car Elevator Construction Parameter

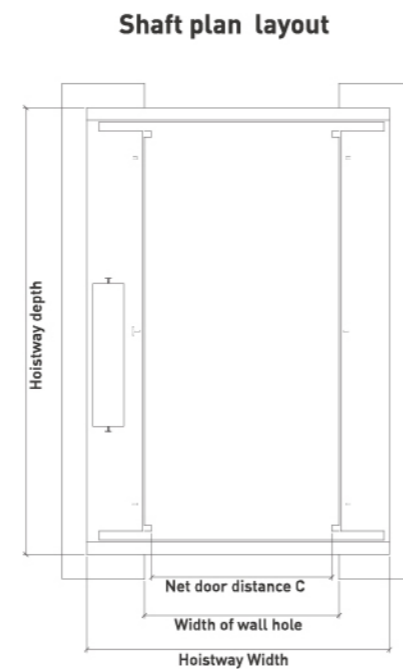
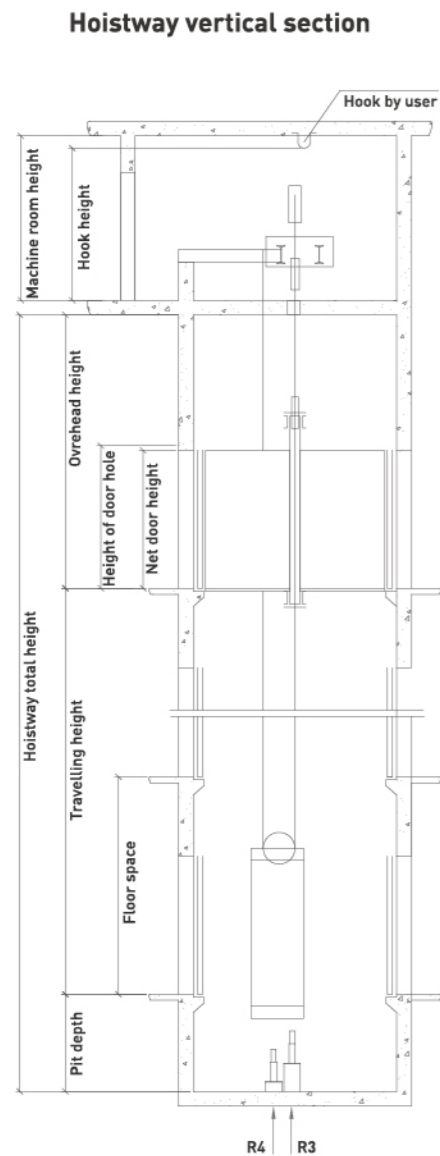

**Car elevator parameters**

Load(kg)	Speed(m/s)	Car dimension(mm)		Floor door(mm)		Hoistway size(mm)				Generator room with one elevator		
		AA	BB	M	HH	AH	BH	PP	OH	AM	BM	HM
3000	0.5	2700	5500	2500	2200	4200	6300	≥1700	≥4500	4200	6000	2800
5000	0.5	3400	7250	2800	2400	4700	7900	≥1700	≥4600	4700	7500	2800

# Escalator Summary

## Urban flavor, charm scene

TENAU serial escalators fully apply the novel materials and the advanced domestic and overseas technology for design and manufacture. The escalators have the consummate structure, elaborate stairway, delicate belt, attractive outline. They are widely applicable for large passenger flow areas such as the shopping centers, supermarkets, subways, airports etc. It adds a charming mobile view for vast constructions.



## Proper and stable running, deluxe and popular design

The large size diameter of step roller operates minimizes the noise and prolongs the product life.

The truss is made of high-quality steel, with unique structure, high strength and nice anti-corruption durable features.



The overall design is concise and smooth and compatible.

The advanced international craftsmanship ensures the accuracy of steps.

The human-oriented handrail entrance is secured by brush.

Etched stainless steel front panels are available with various varieties.

The super CPU main board monitors the operation in real time. If any abnormal situation occurs, it automatically brakes and records the malfunctions code.

The super CPU main board monitors the operation in real time. If any abnormal situation occurs, it automatically brakes and records the malfunctions code.

Customer can choose VVVF control to control running speed, the energy saving performance is obvious. It can prolong product life and reduce the operation cost.



Little noise



High efficiency & energy-saving



More secure



Elegant and attractive

# Moving Walk Summary



## As easy as in smooth ground, the everlasting popular design & quality

TENAU moving walk elevates the shopping to a newly concise and comfortable realm. It not only satisfies the conveying problem of large passenger flow, but also meets the requirements of long-distance walk, carrying luggage cart, baby's cart, shopping cart, the vehicle for the handicapped etc. It is very convenient for people's outing and shopping.

## It merges with modern flavor design and style.

The stairway guiderail design with armrest fixes the whole stairway running in guiderail. It controls the stairway movement, avoids friction amid the step, skirting and comb teeth. It is convenient for installation, adjustment, repair and maintenance. It remarkably increases the running effects.

Incomparable economical: The moving walk fully utilizes advanced manufacturing process, greatly improves product performance and service life, the most direct result is that the operation cost of the customer is reduced. The optional VF drive technology yields great energy-saving, reducing the running cost to the maximum.

Colorful decoration: Various styled handrail can meet personal demand in different environments. Beautiful stainless steel floor plate has a three-dimension effect. Inner and outer decking adopts stainless steel.

Compact structure, ease strain: Short pallets can greatly reduce space span, which can flexibly fits the building structure and save the construction space for the customer. It comprises H version (horizontal), I version (incline) and C version (compact) can let the customer have a free choice on his original layout.



Stable and reliable investment: The pallet directly connecting with the chain which makes the running more smoothly and quietly, thus the service life is extended and its maintenance can be easily conducted. Special designed big wheel handrail drive runs in low noise and big power, which improves the running condition of handrail, its life is hence prolonged. Unique tube structure has a big load capacity, which greatly improves the overall stability and service life.

# Heavy Duty Type Escalator

## When we ascend the crest of our objective, the others appear so small.

TENAU SMEH30 public traffic type escalator is a significant achievement in the innovative steps of TENAU Elevator. The glorious 25m lifting height starts a new highlight in the domestic indoor public traffic type escalator field. It extends the product application to a broader range.

## V-shaped handrail

It reinforces tensile breaking strength, prolongs service life of the handrail, strengthens contact area of handrail rotary end, enlarges handrail friction and effectively drives the handrail movements.

## The roller is outside the step chain

The roller is outside the chain.  $\Phi 100\text{mm}$  is diameter of master and slave wheel. It reduces the compressed load of main wheel and prolongs the roller's service life. The chain applies reinforced materials and structural design with enlarged tensile strength. The roller can be renewed independently so as to save the repair and maintenance period.

## It increases the driving force and turning space

Regarding the turning radius, it largely increases the driving force and turning space of the whole transmission. In addition, it thickens the drive spindle diameter and enables the better bearing capacity.

## Auxiliary brake

Auxiliary brake is in the upper part of the machine room. It uses frictional principle and the auxiliary brake operates through wedge and brake disc that is installed in spindle drive.

## Emergency stop switch

On the basis of setting emergency stop switch in the original upper / lower entry / exit, emergency stop switch also sets every 5 meters of outer cover plate. It is used for sudden events. It can quickly stop the escalator and ensure the passengers' safety too.



## 4 horizontal steps

It applies 4 horizontal steps to enlarge the buffer distance in the travel, therefore the passengers are safer in using the escalators.



## Technical specification of escalator installed in the escalator test tower

Type	Outside type	Heavy duty type (Public transportation type)
Travelling height		25000mm
Horizontal span		51847mm
Inclined angle		30°
Step width		1000mm
Rated speed		0.65m/s

Quantity of flat steps	4
Traction machine power	37KWx2
Inverter power	75KW
Diameter of step main roller	$\Phi 100$
Diameter of step secondary roller	$\Phi 100$
Handrail drive mode	Sprocket-driven

# Escalator Safety Device

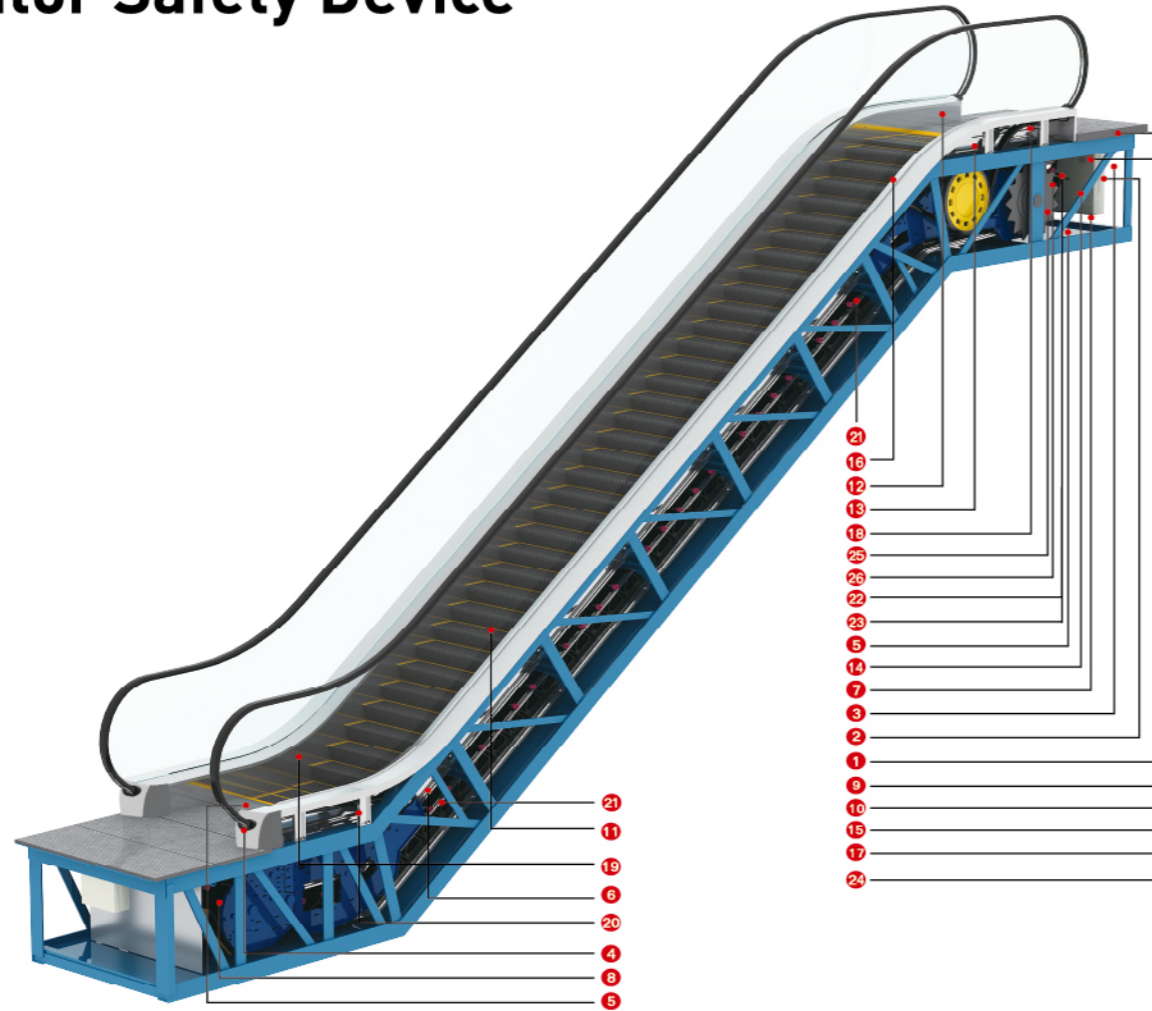

Standard function	Description of functions
1.Lack of phase, error phase protection	if lack of phase or error phase has been checked out, the escalator (passenger conveyor) will automatically stop the operation.
2.Motor over-load protection	When the current exceeds 15% of the current rating, the escalator will automatically stop the operation.
3.Electrical appliance loop protection	It offers the automatic circuit disconnecting device to protect the circuit and mains components of the escalator (passenger conveyor).
4.Handrail inlet protection	When some foreign substance has been clipped in the handrail inlet, the escalator (passenger conveyor) will automatically stop the operation.
5.Comb plate safety device	When some foreign substance has been clipped in or between the combs, the escalator (passenger conveyor) will automatically stop the operation.
6.Step sagging protection device	When there is abnormal step bending, the escalator (passenger conveyor) will stop the operation before the step entering into the comb plate.
7.Broken drive-chain safety device	when the drive-chain has been over-stretched or it is broken, the escalator (passenger conveyor) will automatically stop the operation.
8.Broken step chain protection	When the step (plate) chain has been over-stretched or it is broken, the escalator (passenger conveyor) will automatically stop the operation.
9.Over-speed protection	When there is over-speed to the escalator (passenger conveyor), it will automatically stop the operation.
10.Direction reversal protection	When it comes the unintentional reversal of the direction of travel, the escalator (passenger conveyor) will automatically stop the operation.
11.Security line	The yellow synthetic resin security line is located in the front position and two sides of the escalator tread so that the passengers will not tread in-between the edge of the adjacent step and the lift group lengthened skirt panel. The security line on both sides of the step is higher than the tread surface. [The passenger conveyor offers the selective yellow spray-painted security line.]
12.Emergency stop button	When the button has been pressed down, the escalator (passenger conveyor) will stop the operation.
13.Skirt panel protection	When some foreign substance has been clipped in between the skirt panel and the step, the escalator (passenger conveyor) will automatically stop the operation.

# Moving Walk Safety Device

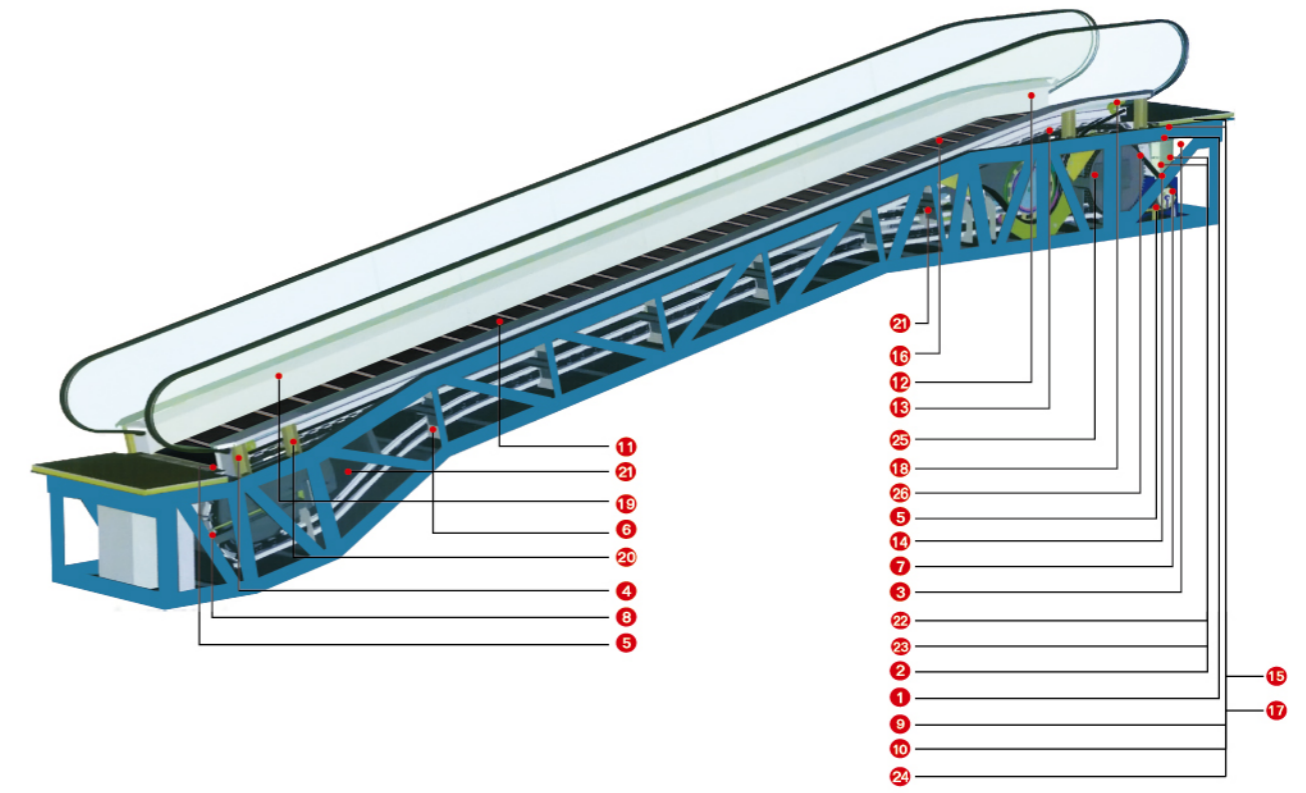

14.Brake protection	When the electric force falls short of supply or it acts any of the safety device, the brake function goes into effect by the safety device through the spring resilience action. In this way, the escalator (passenger conveyor) stops the operation.			
15.Safety inspection switch	It is a safety device to prevent from the escalator starting during the inspection and maintenance.			
16.Step illumination	Illumination exists in the upper and lower ends of the escalator, in the lower part of the step in order to remind the passengers of the security matters.			
17.Alarm bell starting device	The alarm bell rings when it starts the escalator in order to remind the passengers of the security matters.			
18.Control device for handrail breakage	When the handrail is broken, the escalator will automatically stop the operation.			
19.Skirt panel brush	The brush that has been installed between the skirt panel and the step will prevent the passengers from touching the skirt panel. [It is not merely restricted to the escalator.]			
20.Anti - static electricity device of the handrail belt	21.Anti - static electricity device of the steps board	22.The steps (pedal) loss protection	23.Fault display	24.Automatic refueling function

Option functions	Description of functions
25.VVF variable frequency energy-saving system	When chooses the frequency converter,it can effectively reduce the energy consumption.
26.Comb illumination	The illumination has been installed in the skirt panel near the comb plate. It offers the lighting for the step and the comb plate. It is more convenient for the passengers to up and down the escalator.
27.Handrail illumination	The handrail illumination has been installed in the handrail frame. The gentle light adds charm to the running escalator.
28.Automatic start / stop	The infrared ray sensor which is near the floor plate can detect the passenger that enter into the floor plate. Then it will automatically start the operation. After all the passengers leave, it will automatically stop the operation again in order to save the energy loss. Scanning sensor and traditional guide rod are available for your choice.
29.Fail-safe brake	When the chain drive breaks or the steps and handrail operating in the opposite direction of the specified direction, the assistant brake will cease the escalator. When the height of the escalator is over 6 meters, or on the pavement, it is necessary to be equipped with this device.

# Standard & Optional Function

TENAU escalator / moving walk utilize multiple cutting-edge technologies to offer rich and varied functions for users to choose based on their needs. They fully satisfy the needs for new life in the future.

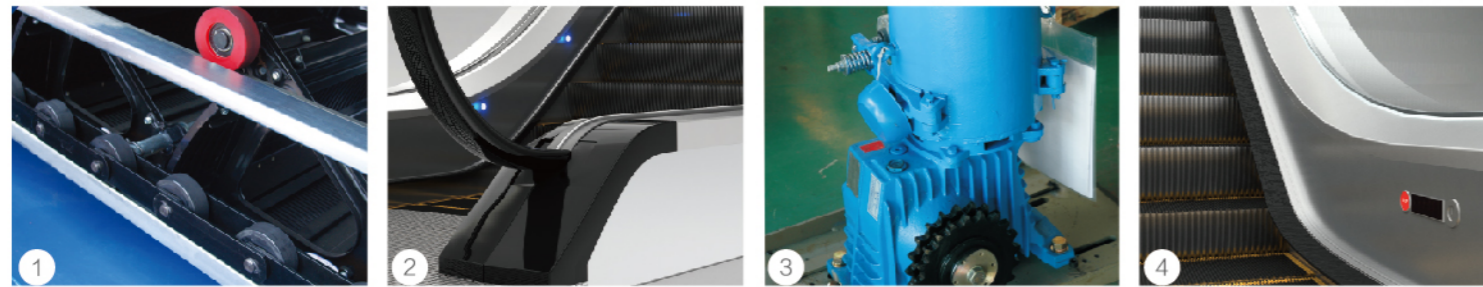

## 1 Step chain-roller inbuilt (standard)

The roller has been internally installed in the specially-designed roller step chain. It can effectively fulfill the reduction of the noise during the driving process and bring about a more smooth and quiet operation.

## 2 Handrail inlet (standard)

Novel, trendy and attractive design for the entrance and exit of the handrail belt makes the escalators more live and amicable.

## 3 Vertical type traction machine (standard)

Higher transmission effectiveness, lower noise and longer service hours.

## 4 Moving directions and failure display (standard)

By means of observing the digital readings on the displaying plates mounted on both sides of the skirts board at the entrance and exit of the escalator (or moving walks), the maintenance work can be made promptly and easily.

## 5 Illumination for the passengers (standard)

Green light softly beams out from the space between the engaged teeth of the two neighboring steps to remind the passengers to be aware of the level sections both at the entrance and exit, resulting in increased security for the passengers.

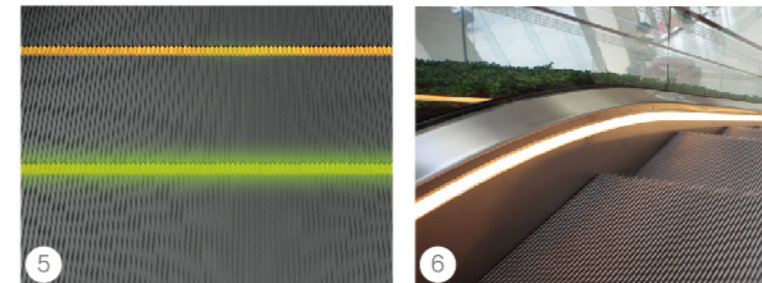

## 6 Emergency brake device (optional)

The skirt board illumination arranged along side the steps' arc moving contour makes the passengers feel more comfortable and safe.

## 7 Heating device (optional)

Each escalator usually installs three heating devices. One is beside the host in the upper machine room. It mainly heats the host. The second is installed in the mid escalator. And the third is in the lower part. It mainly heats the whole escalator.

## 8 Variable frequency driving-VVVF (optional)

When there's no load, the escalator (or moving walk) moves at low speed and when the approach of a passenger is detected, it restores to the normal speed. This shows conspicuous energy saving effects, saving up to 40% of power.

## 9 Electric automatic lubrication (optional)

Controlled by PC, the lubricating signals are emitted after a preset period when the hydraulic pump is automatically activated to conduct the lubrication.

## 10 Running direction indication (optional)

The running direction and forbidden display mark have been placed in the inlet and outlet of the handrail. The obvious running or forbidden instruction ensures the safe riding of the passengers with great ease.



# 30° Escalator Construction Parameter

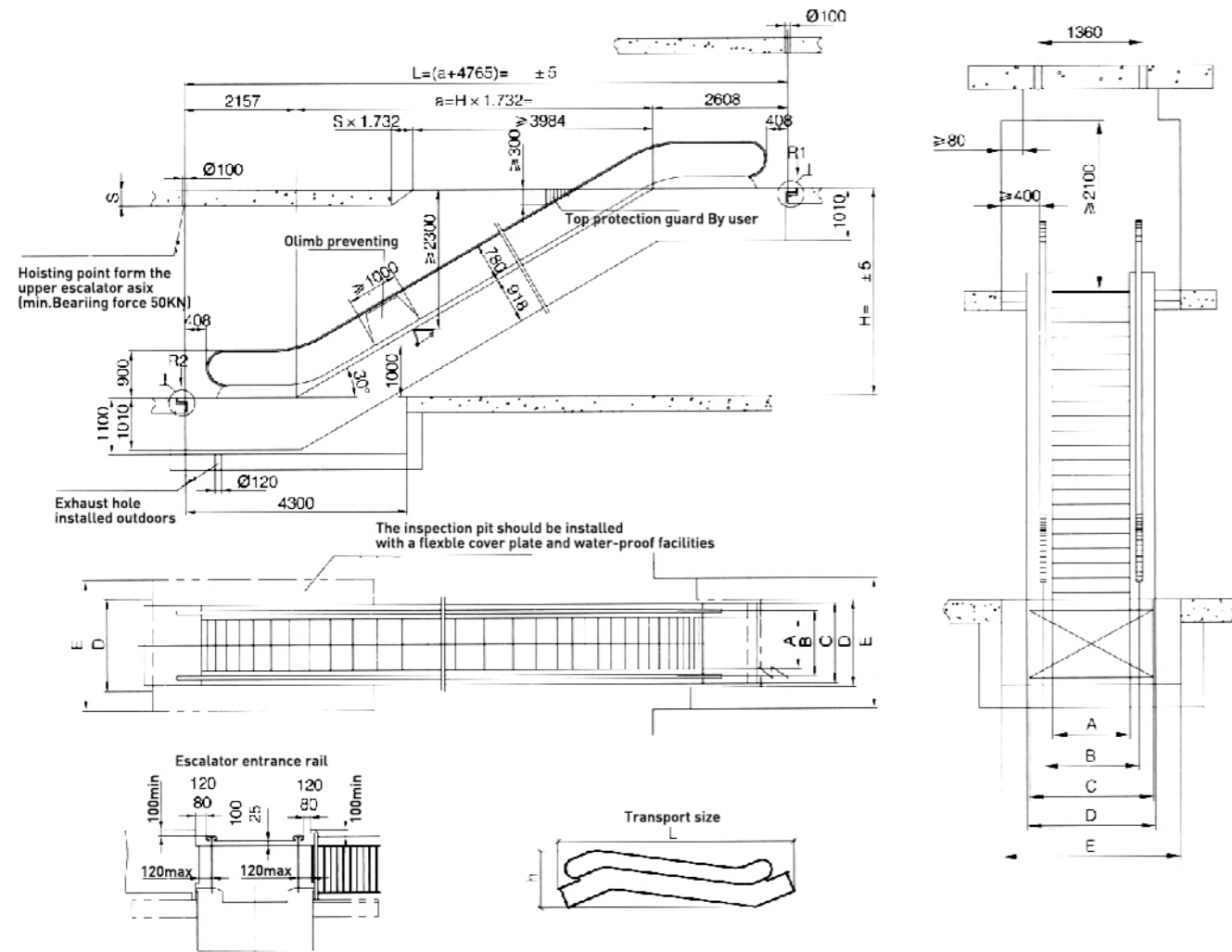

# 35° Escalator Construction Parameter

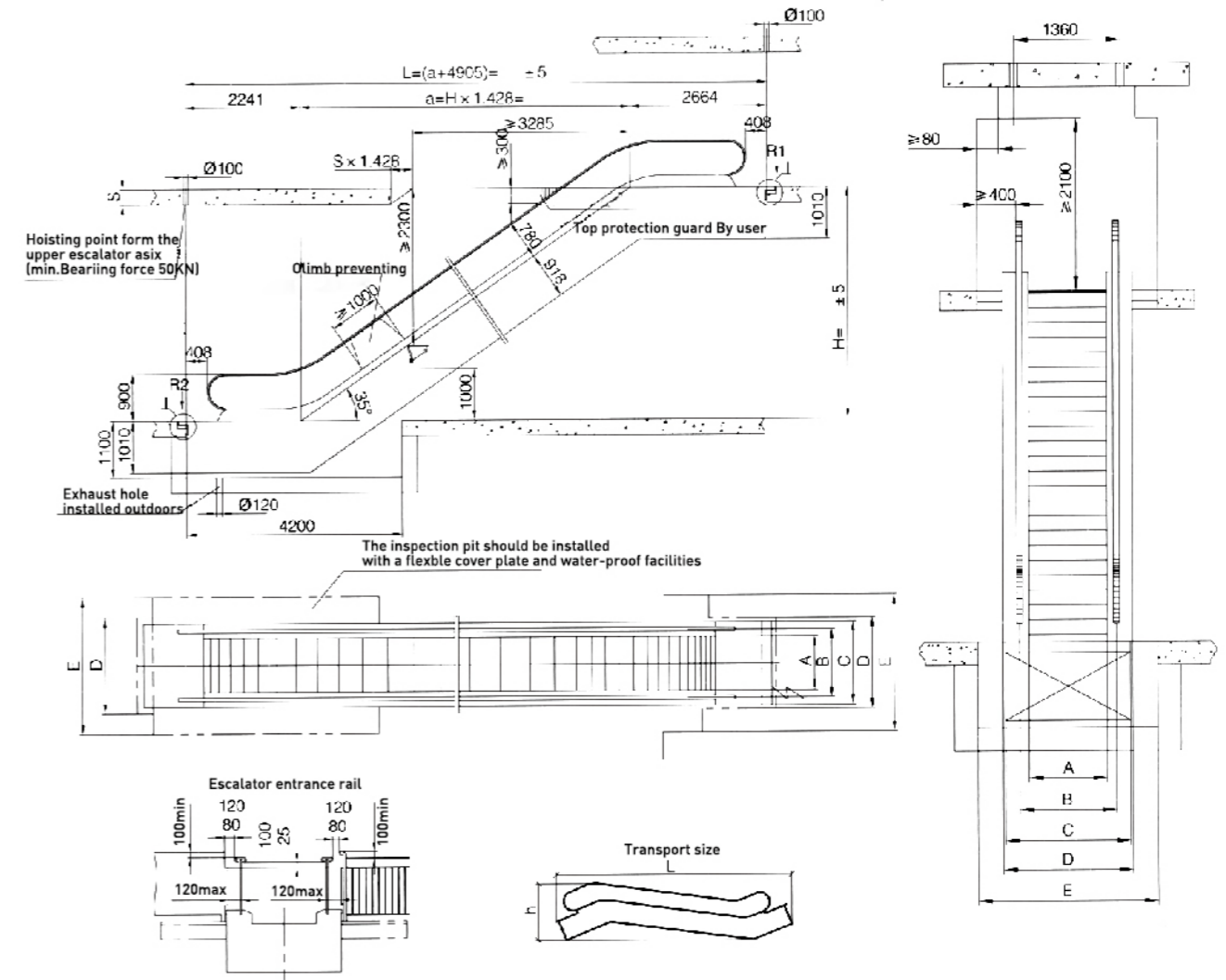

Model	Travelling height(mm)	Net weight KN	Supporting		Motor power	Transport size	
			R1 KN	R2 KN		H	L
SEM(600)-30 (4500 Per./h) speed 0.5m/s	3000	57	46	41	8	2750	10900
	3500	60	49	44		2780	11890
	4000	64	52	47		2810	12880
	4500	68	56	50		2830	13870
	5000	71	59	53		2840	14860
	5500	75	62	56		2860	15860
SEM(800)-30 (6750 Per./h) speed 0.5m/s	3000	59	52	47	8	2750	10900
	3500	63	56	50		2780	11890
	4000	67	60	54		2810	12880
	4500	71	64	57	11	2830	13870
	5000	74	68	60		2840	14860
	5500	82	74	66		2860	15860
SEM(1000)-30 (9000 Per./h) speed 0.5m/s	3000	63	59	53	8	2750	10900
	3500	67	64	57		2780	11890
	4000	71	68	61		2810	12880
	4500	75	73	65	11	2830	13870
	5000	83	79	71		2840	14860
	5500	87	84	75		2860	15860
6000	92	88	79		2870	16860	

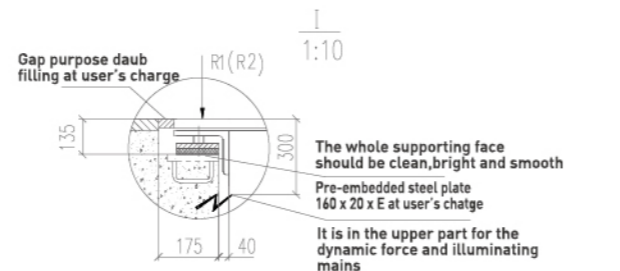

Step width	A	B	C	D	E	F
1000	1000	1158	1238	1600	1660	2310
800	800	958	1038	1400	1460	2110
600	600	758	838	1200	1260	1910

Model	Travelling height(mm)	Net weight KN	Supporting		Motor power	Transport size	
			R1 KN	R2 KN		H	L
SEM(600)-35 (4500 Per./h) speed 0.5m/s	3000	54	43	39	8	2850	10180
	3500	57	46	41		2890	11030
	4000	60	59	44		2920	11890
	4500	64	52	46		2940	12750
	5000	67	54	49		2970	13610
	5500	70	57	51		2980	14470
SEM(800)-35 (6750 Per./h) speed 0.5m/s	3000	56	49	44	8	2850	10180
	3500	60	52	47		2890	11030
	4000	63	56	50		2920	11890
	4500	66	59	53	11	2940	12750
	5000	70	62	56		2970	13610
	5500	73	65	59		2980	14470
SEM(1000)-35 (9000 Per./h) speed 0.5m/s	3000	60	56	50	8	2850	10180
	3500	64	60	53		2890	11030
	4000	67	64	57		2920	11890
	4500	71	67	60	11	2940	12750
	5000	74	71	64		2970	13610
	5500	82	77	69		2980	14470
6000	85	81	72		3000	15330	

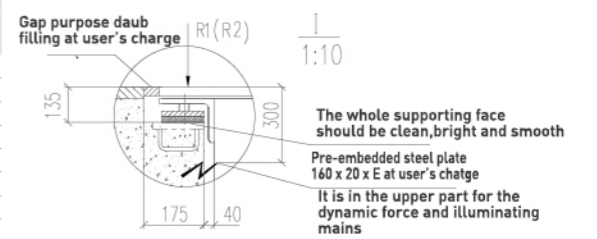

Step width	A	B	C	D	E	F
1000	1000	1158	1238	1600	1660	2310
800	800	958	1038	1400	1460	2110
600	600	758	838	1200	1260	1910

# 12° Moving Walk Construction Parameter

# 0° Moving Walk Construction Parameter

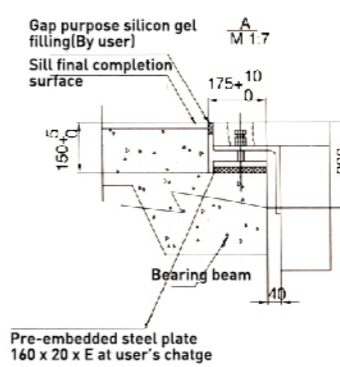
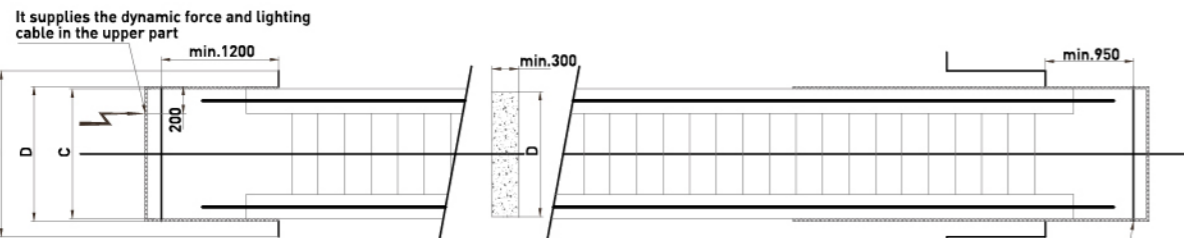
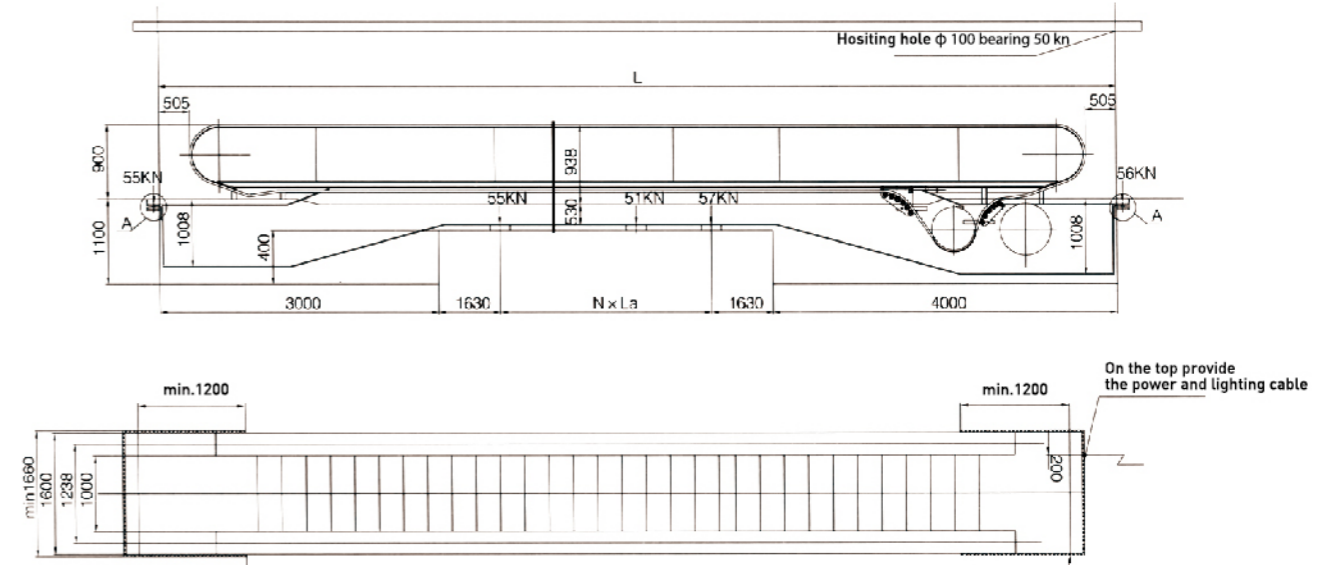
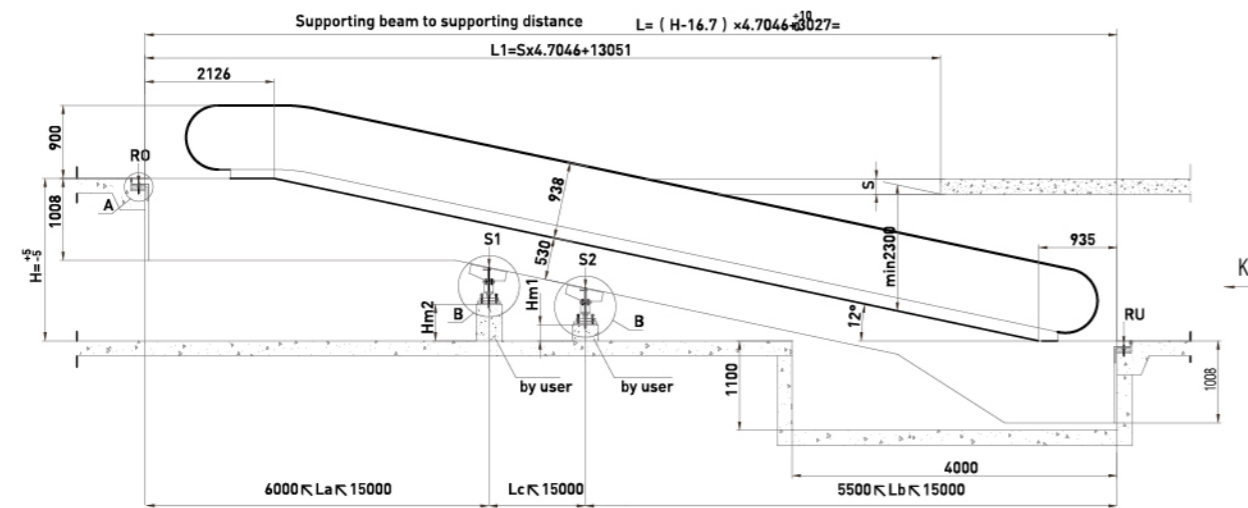

It should fill or cover the gap between the machine and the construction. The user should take care of the standard which is applicable for the well width

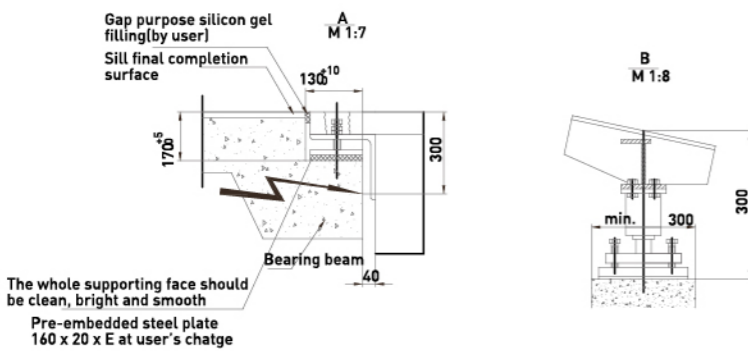

It should fill or cover the gap between the machine and the construction. The user should take care of the standard which is applicable for the well width

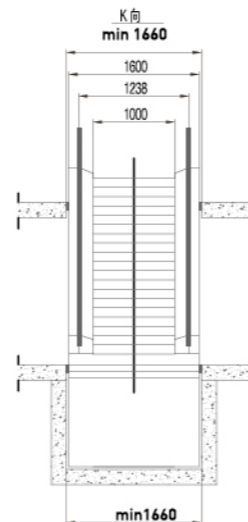

The construction supporting force includes the vibration load

No intermediate supporting		One intermediate supporting		Two intermediate supporting	
$R_0 = 0.0045XL + 13$		$R_0 = 0.0045XL + 13$		$R_0 = 0.0045XL + 13$	
$R_U = 0.0045XL + 7$		$R_U = 0.0045XL + 7$		$R_U = 0.0045XL + 7$	
$S_1 = 0.00585X(La + Lb)$		$S_1 = 0.00585X(La + Lc)$		$S_2 = 0.00585X(Lb + Lc)$	
Travelling height	Intermediate supporting	La (mm)	Lb (mm)	Lc (mm)	Intermediate supporting height
From To	S1 S2				
1601 2663	- -	-	-	-	Hm1 0.2126xLb-1051
2664 4151	1 -	L-7000	7000	-	
4152 5851	1 -	15000	L-15000	-	
5852 6000	1 1	15000	7000	L-22000	Hm2 0.2126x(Lb+Lc)-1066

Model	Travelling height (mm)	Rated speed	Rated load capacity	Inclination	Motor power	A (mm)	B (mm)	C (mm)	D (mm)
SMEH (800/0°)	80000	0.5	6750	0	5.5	800	1038	1400	≥ 1460
	80000 < L ≤ 130000				8				
	130000 < L ≤ 150000				11				
SMEH (1000/0°)	70000	0.5	9000	0	5.5	1000	1238	1600	≥ 1660
	70000 < L ≤ 110000				8				
	110000 < L ≤ 150000				11				